

PARTS LIST					
ITEM	QTY	PART NO.	PART DESCRIPTION	UNIT WT.	NET WT.
1	3	VFA10-XDS-A3	HEAVY S1-10-3 10' NOMINAL SECTOR FRAME W/ 3 MAST PIPES	847.27	2541.81
TOTAL WT. #					2541.81

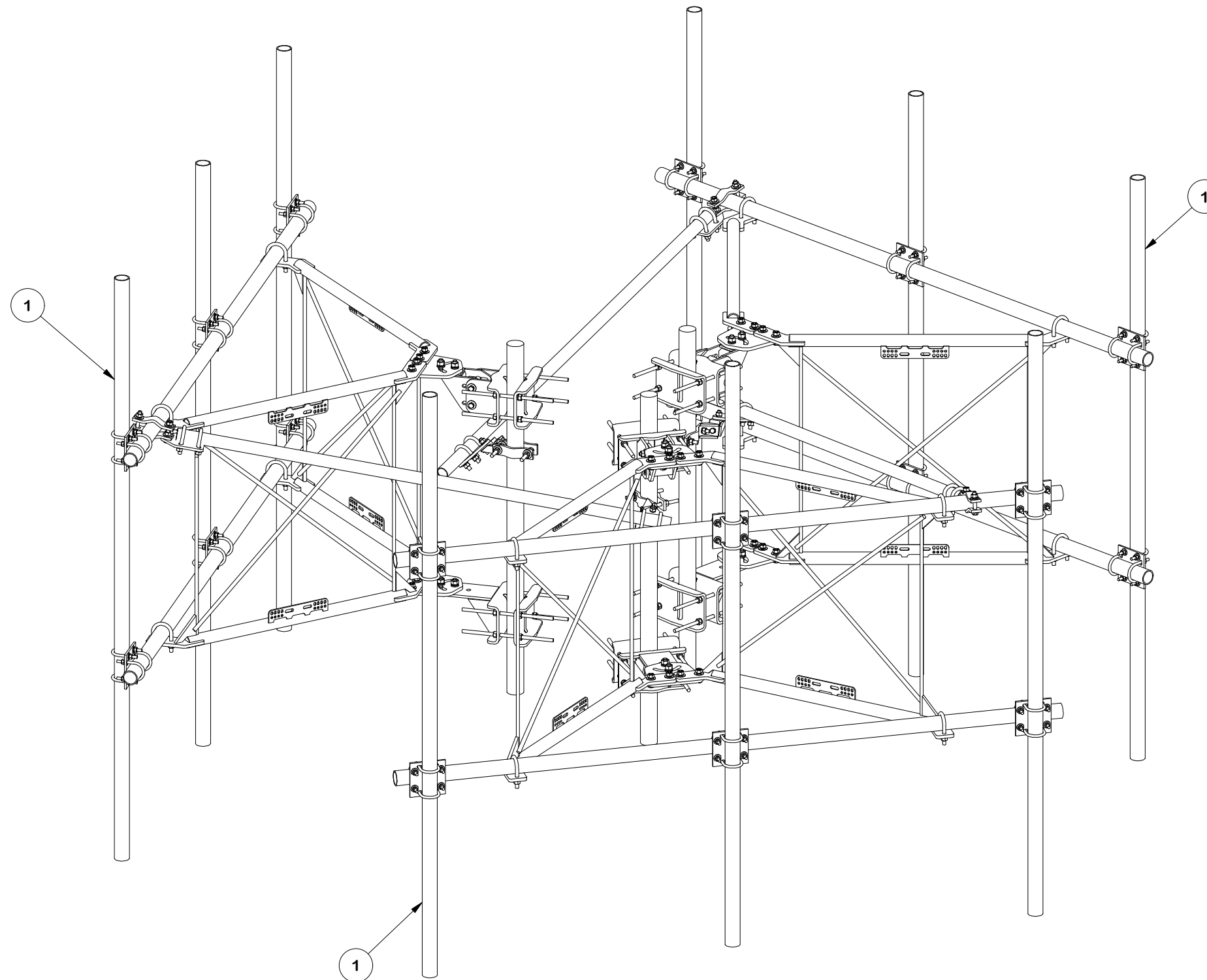

**TOLERANCE NOTES**

TOLERANCES ON DIMENSIONS, UNLESS OTHERWISE NOTED ARE:  
 SAWED, SHEARED AND GAS CUT EDGES ( $\pm 0.030"$ )  
 DRILLED AND GAS CUT HOLES ( $\pm 0.030"$ ) - NO CONING OF HOLES  
 LASER CUT EDGES AND HOLES ( $\pm 0.010"$ ) - NO CONING OF HOLES  
 BENDS AND ANGLES ARE  $\pm 1/2$  DEGREE  
 ALL OTHER MACHINING ( $\pm 0.030"$ )  
 ALL OTHER ASSEMBLY ( $\pm 0.060"$ )

PATENT INFORMATION: WWW.SITEPRO1.COM/PATENTS

PROPRIETARY NOTE:  
 THE DATA AND TECHNIQUES CONTAINED IN THIS DRAWING ARE PROPRIETARY INFORMATION OF VALMONT INDUSTRIES AND CONSIDERED A TRADE SECRET. ANY USE OR DISCLOSURE WITHOUT THE CONSENT OF VALMONT INDUSTRIES IS STRICTLY PROHIBITED.

DESCRIPTION  
**HEAVY S3-10-3  
 3 - 10' NOMINAL SECTOR FRAME KIT WITH  
 SELF-SUPPORTED / GUYED ATTACHMENT**

CPD NO.	DRAWN BY	ENG. APPROVAL
NCS	ADB 8/19/2025	8/22/2025
CLASS	DRAWING USAGE	CHECKED BY
87	CUSTOMER	JET 8/22/2025



Engineering Support Team:  
 sp1engineering@valmont.com

PART NO.	VFA10-XDS3-A9
DWG. NO.	VFA10-XDS3-A9

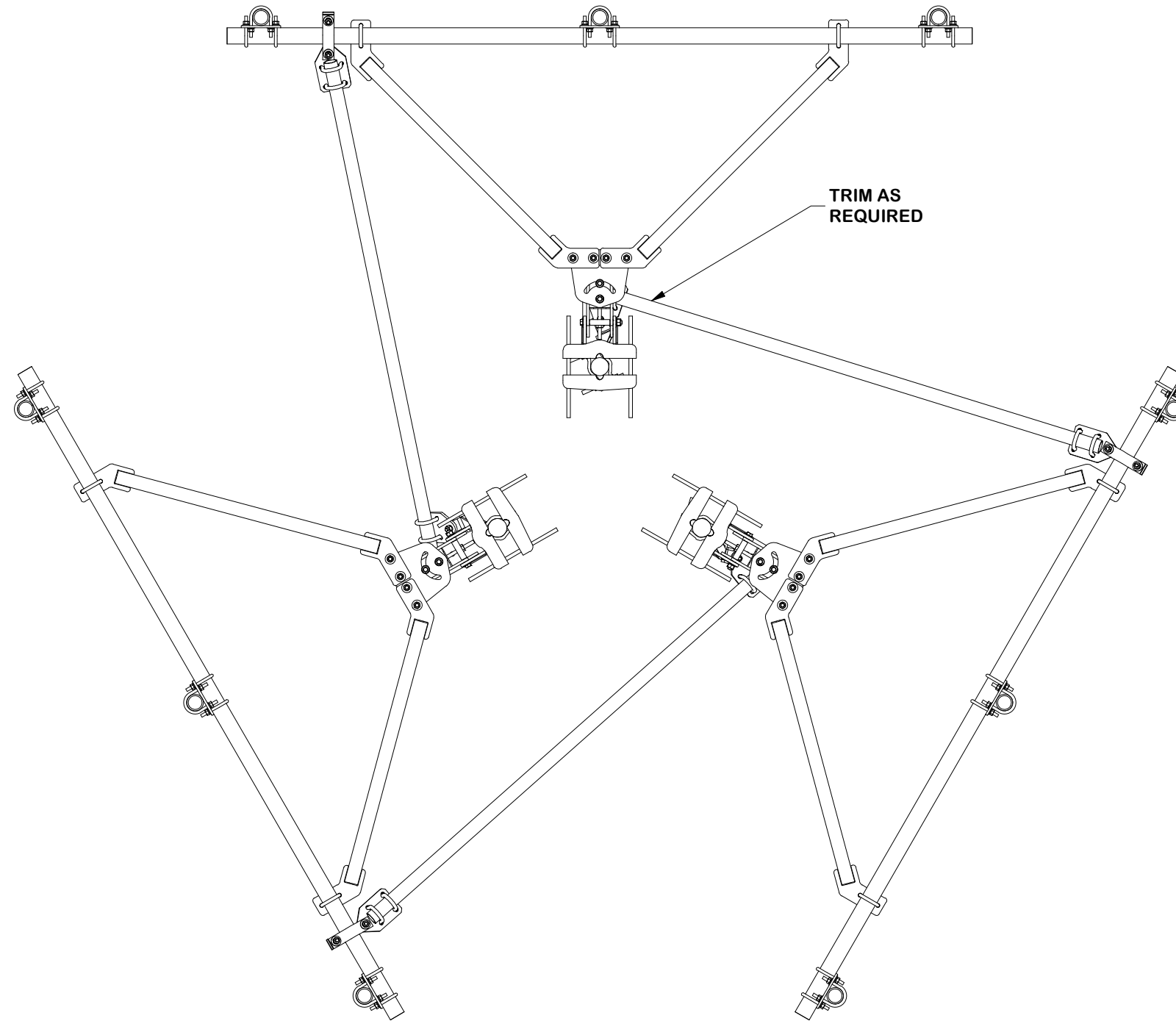

**TOLERANCE NOTES**

TOLERANCES ON DIMENSIONS, UNLESS OTHERWISE NOTED ARE:  
 SAWED, SHEARED AND GAS CUT EDGES ( $\pm 0.030"$ )  
 DRILLED AND GAS CUT HOLES ( $\pm 0.030"$ ) - NO CONING OF HOLES  
 LASER CUT EDGES AND HOLES ( $\pm 0.010"$ ) - NO CONING OF HOLES  
 BENDS AND ANGLES ARE  $\pm 1/2$  DEGREE  
 ALL OTHER MACHINING ( $\pm 0.030"$ )  
 ALL OTHER ASSEMBLY ( $\pm 0.060"$ )

PATENT INFORMATION: WWW.SITEPRO1.COM/PATENTS

PROPRIETARY NOTE:  
 THE DATA AND TECHNIQUES CONTAINED IN THIS DRAWING ARE PROPRIETARY INFORMATION OF VALMONT INDUSTRIES AND CONSIDERED A TRADE SECRET. ANY USE OR DISCLOSURE WITHOUT THE CONSENT OF VALMONT INDUSTRIES IS STRICTLY PROHIBITED.

DESCRIPTION  
**HEAVY S3-10-3**  
**3 - 10' NOMINAL SECTOR FRAME KIT WITH**  
**SELF-SUPPORTED / GUYED ATTACHMENT**

CPD NO. <b>NCS</b>	DRAWN BY <b>ADB 8/19/2025</b>	ENG. APPROVAL <b>8/22/2025</b>
CLASS <b>87</b>	SUB <b>02</b>	DRAWING USAGE <b>CUSTOMER</b>
	CHECKED BY <b>JET 8/22/2025</b>	



Engineering Support Team:  
 sp1engineering@valmont.com

A valmont COMPANY

PART NO. <b>VFA10-XDS3-A9</b>	PAGE <b>2 OF 17</b>
DWG. NO. <b>VFA10-XDS3-A9</b>	

PARTS LIST						
ITEM	QTY	PART NO.	PART DESCRIPTION	LENGTH	UNIT WT.	NET WT.
1	2	X-VXDW45	XTREME DUTY 45" VERTICAL SUPPORT ARM		100.07	200.13
2	1	BCAM-HD	HEAVY DUTY BOLT CALIBRATED ANGLE MAINSTAY		147.01	147.01
3	1	SPTB	SLIDING TIE-BACK ASSEMBLY KIT		91.18	91.18
4	1	VFAPL4-K	HD FRAME PIVOT PLATE KIT		39.25	39.25
6	3	P30120	2-7/8" x 120" (2-1/2" SCH. 40) GALVANIZED PIPE	120 in	58.07	174.20
5	2	P30132	2-7/8" X 132" (2-1/2" SCH. 40) GALVANIZED PIPE	132 in	67.70	135.41
7	6	SCX23-K	CROSSOVER PLATE KIT 2-7/8" X 2-7/8"		9.00	53.97
8	4	X-UB5300	5/8" X 3" X 5-1/4" X 2-1/2" U-BOLT	5 1/4 in	1.22	4.87
9	8	G58LW	5/8" HDG LOCKWASHER		0.03	0.21
10	8	G58NUT	5/8" HDG HEAVY 2H HEX NUT		0.13	1.04
					TOTAL WT. #	847.27

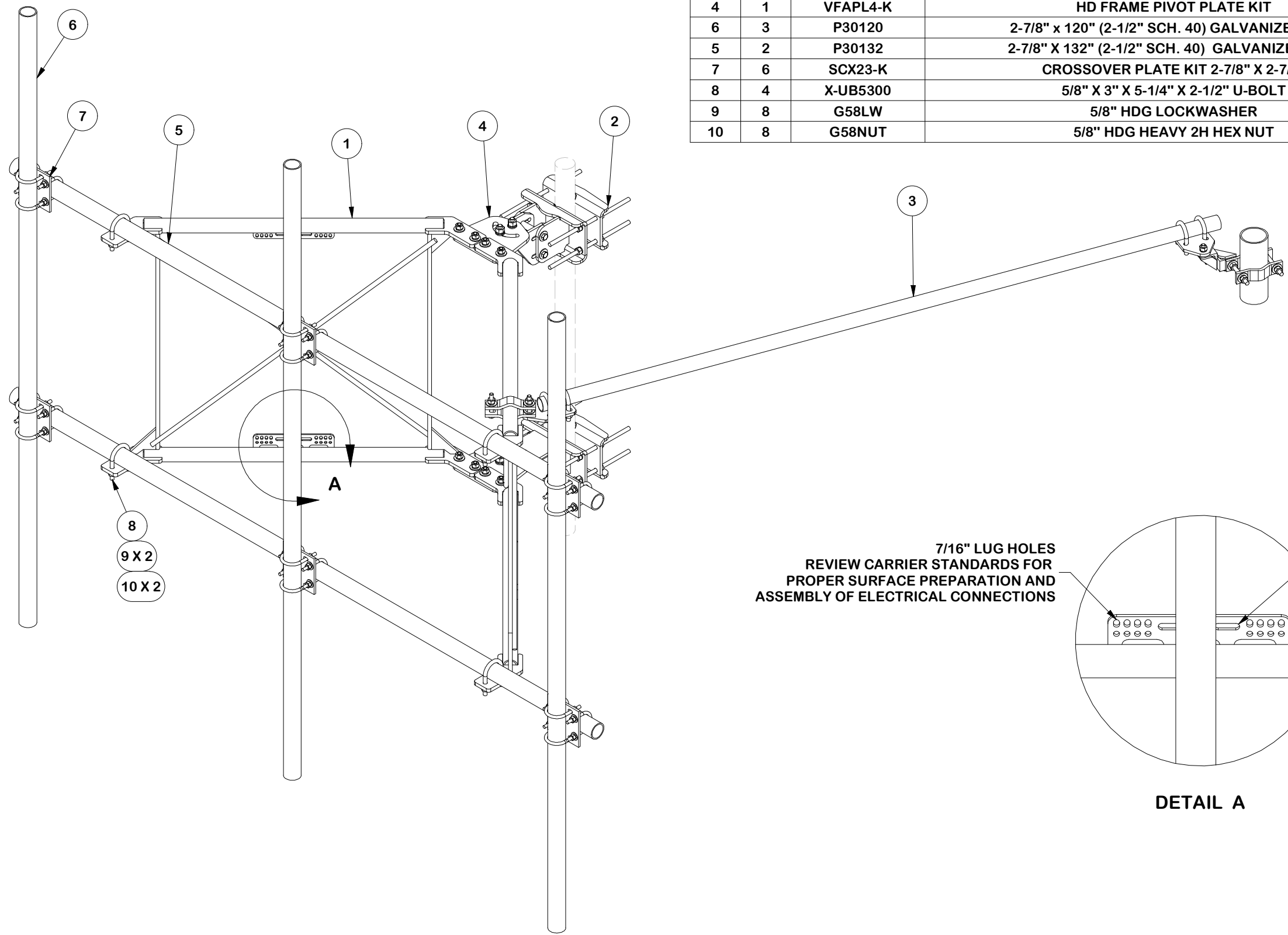

7/16" LUG HOLES  
REVIEW CARRIER STANDARDS FOR  
PROPER SURFACE PREPARATION AND  
ASSEMBLY OF ELECTRICAL CONNECTIONS

9/16" SLOTTED HOLE FOR  
EQUIPMENT PIPE HARDWARE

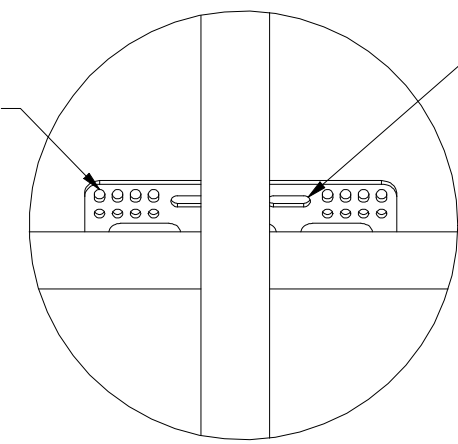

DETAIL A

**TOLERANCE NOTES**  
TOLERANCES ON DIMENSIONS, UNLESS OTHERWISE NOTED ARE:  
SAWED, SHEARED AND GAS CUT EDGES ( $\pm 0.030"$ )  
DRILLED AND GAS CUT HOLES ( $\pm 0.030"$ ) - NO CONING OF HOLES  
LASER CUT EDGES AND HOLES ( $\pm 0.010"$ ) - NO CONING OF HOLES  
BENDS AND ANGLES ARE  $\pm 1/2$  DEGREE  
ALL OTHER MACHINING ( $\pm 0.030"$ )  
ALL OTHER ASSEMBLY ( $\pm 0.060"$ )

PATENT INFORMATION: WWW.SITEPRO1.COM/PATENTS

PROPRIETARY NOTE:  
THE DATA AND TECHNIQUES CONTAINED IN THIS DRAWING ARE PROPRIETARY INFORMATION OF VALMONT INDUSTRIES AND CONSIDERED A TRADE SECRET. ANY USE OR DISCLOSURE WITHOUT THE CONSENT OF VALMONT INDUSTRIES IS STRICTLY PROHIBITED.

DESCRIPTION  
**HEAVY S3-10-3  
3 - 10' NOMINAL SECTOR FRAME KIT WITH  
SELF-SUPPORTED / GUYED ATTACHMENT**

CPD NO. <b>NCS</b>	DRAWN BY <b>ADB 8/19/2025</b>	ENG. APPROVAL <b>8/22/2025</b>
CLASS <b>87</b>	SUB <b>02</b>	DRAWING USAGE <b>CUSTOMER</b>
CHECKED BY <b>JET 8/22/2025</b>		

**SITE PRO 1**  
A valmont COMPANY

Engineering Support Team:  
sp1engineering@valmont.com

PART NO. <b>VFA10-XDS-A3</b>	PAGE <b>3 OF 17</b>
DWG. NO. <b>VFA10-XDS3-A9</b>	

**NOTE: ALL COMPONENTS AND  
HARDWARE SOLD SEPERATELY**

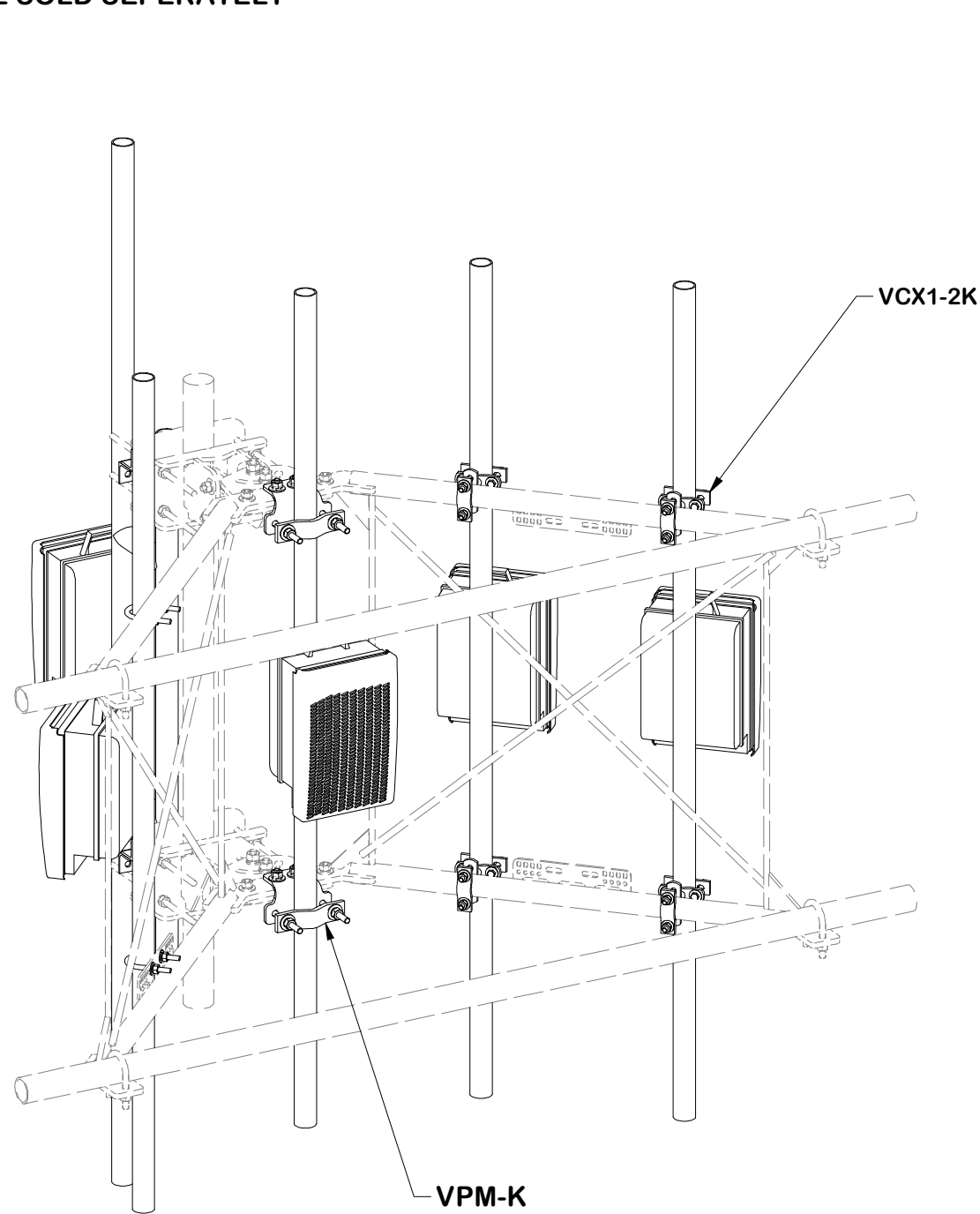

**FRONT ISO**

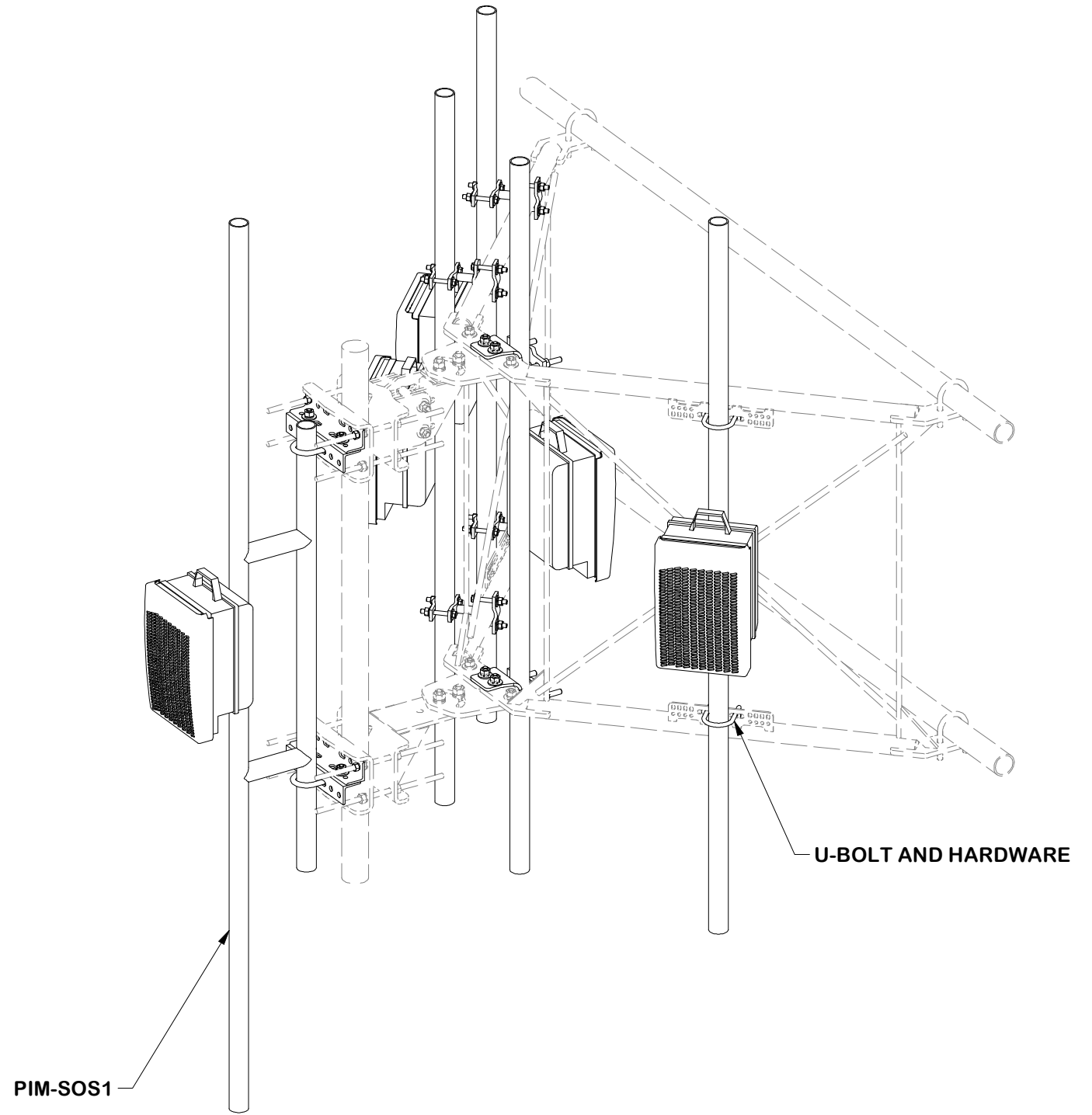

**REAR ISO**

**TOLERANCE NOTES**

TOLERANCES ON DIMENSIONS, UNLESS OTHERWISE NOTED ARE:  
 SAWED, SHEARED AND GAS CUT EDGES ( $\pm 0.030"$ )  
 DRILLED AND GAS CUT HOLES ( $\pm 0.030"$ ) - NO CONING OF HOLES  
 LASER CUT EDGES AND HOLES ( $\pm 0.010"$ ) - NO CONING OF HOLES  
 BENDS AND ANGLES ARE  $\pm 1/2$  DEGREE  
 ALL OTHER MACHINING ( $\pm 0.030"$ )  
 ALL OTHER ASSEMBLY ( $\pm 0.060"$ )

PATENT INFORMATION: WWW.SITEPRO1.COM/PATENTS

PROPRIETARY NOTE:  
 THE DATA AND TECHNIQUES CONTAINED IN THIS DRAWING ARE PROPRIETARY INFORMATION OF VALMONT INDUSTRIES AND CONSIDERED A TRADE SECRET. ANY USE OR DISCLOSURE WITHOUT THE CONSENT OF VALMONT INDUSTRIES IS STRICTLY PROHIBITED.

DESCRIPTION  
**HEAVY S3-10-3  
 3 - 10' NOMINAL SECTOR FRAME KIT WITH  
 SELF-SUPPORTED / GUYED ATTACHMENT**

CPD NO. <b>NCS</b>	DRAWN BY <b>ADB 8/19/2025</b>	ENG. APPROVAL <b>8/22/2025</b>
CLASS <b>87</b>	SUB <b>02</b>	DRAWING USAGE <b>CUSTOMER</b>
	CHECKED BY <b>JET 8/22/2025</b>	



Engineering  
 Support Team:  
 sp1engineering@valmont.com

A valmont COMPANY

PART NO. <b>VFA RRU REF</b>
DWG. NO. <b>VFA10-XDS3-A9</b>

# 3 ANTENNA SECTOR FRAME LAYOUT

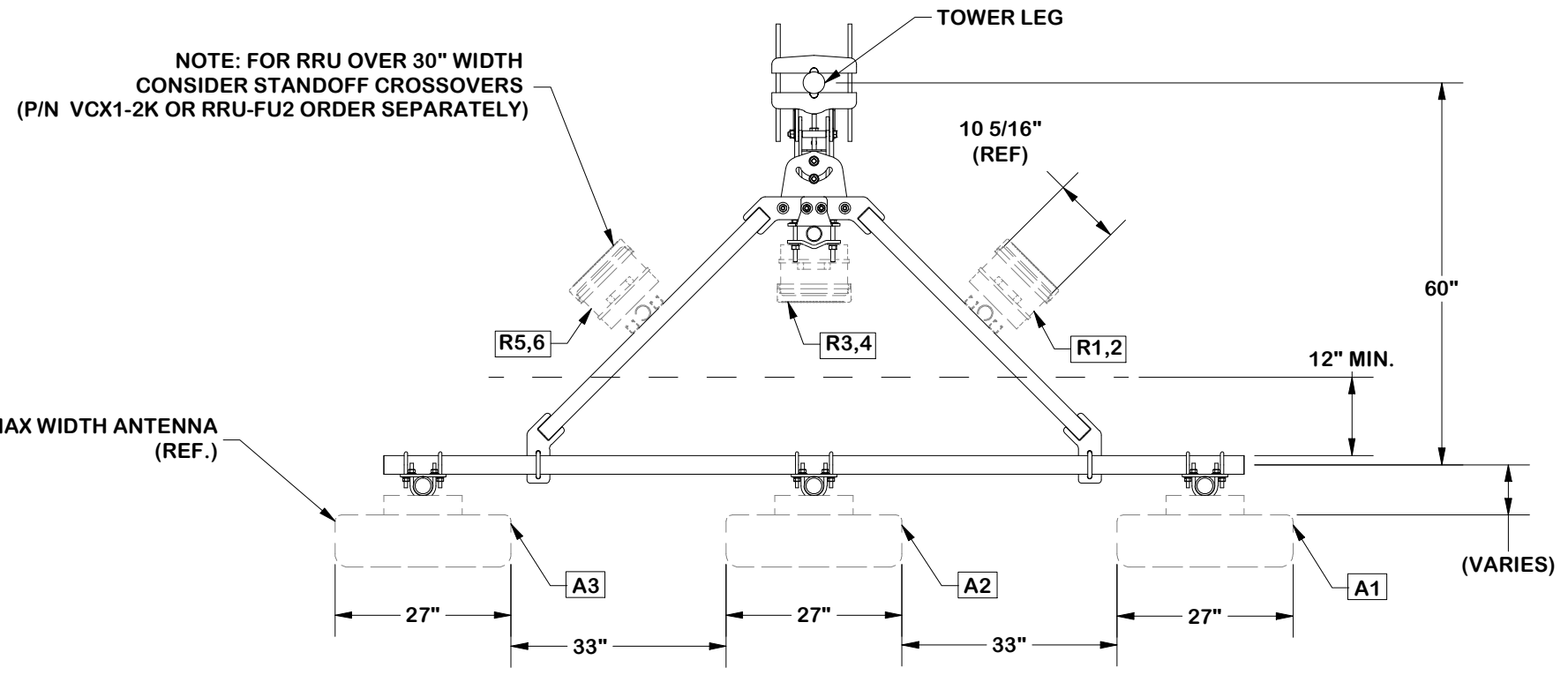

TOP VIEW

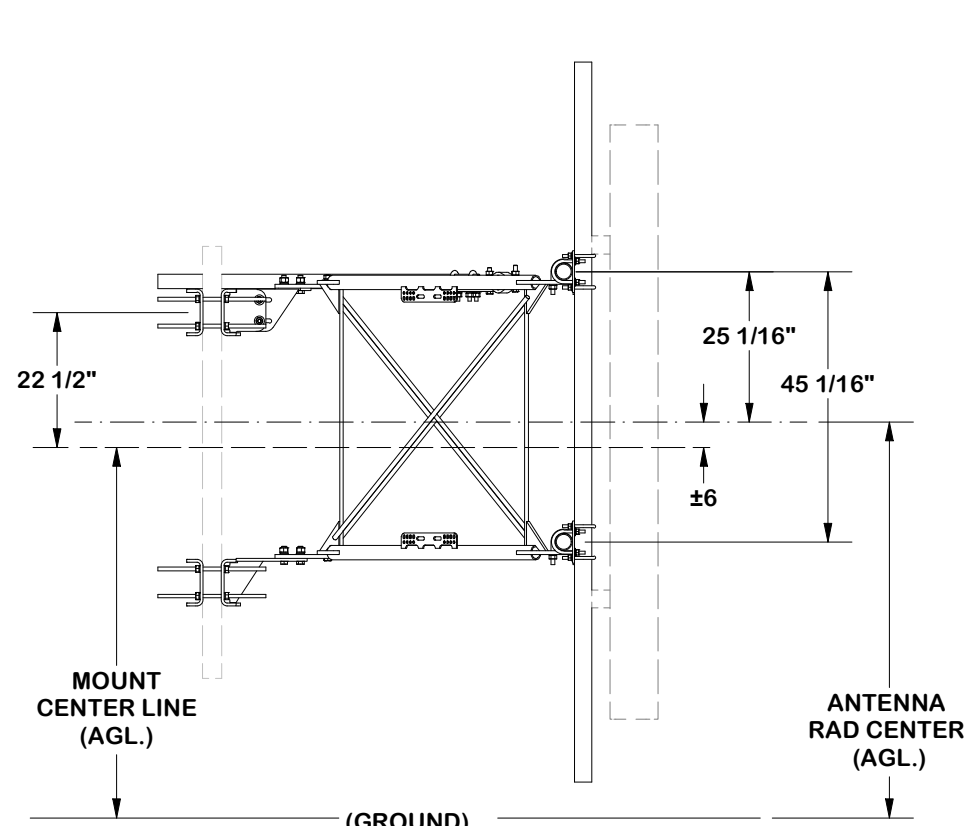

SIDE VIEW

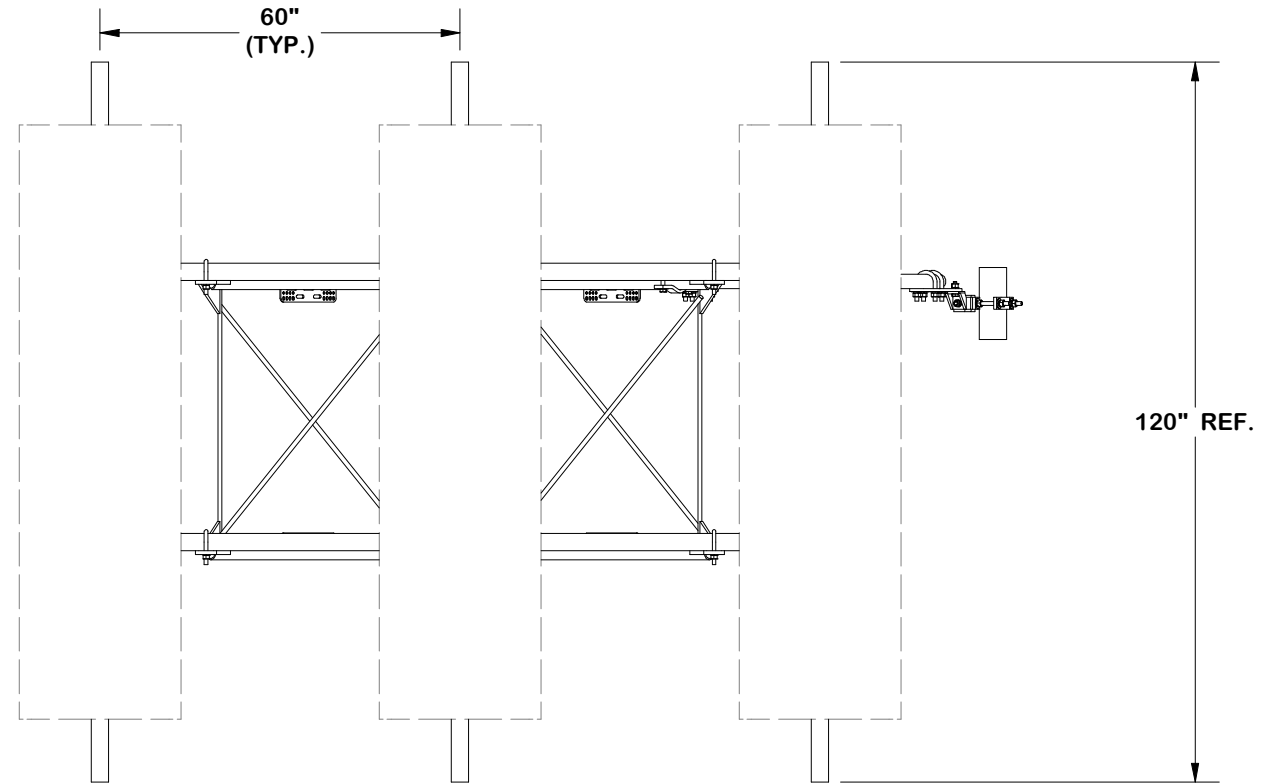

FRONT VIEW

[ATT-790-202-083 MACRO BUILD COMPLIANT]

## TOLERANCE NOTES

TOLERANCES ON DIMENSIONS, UNLESS OTHERWISE NOTED ARE:  
 SAWED, SHEARED AND GAS CUT EDGES ( $\pm 0.030"$ )  
 DRILLED AND GAS CUT HOLES ( $\pm 0.030"$ ) - NO CONING OF HOLES  
 LASER CUT EDGES AND HOLES ( $\pm 0.010"$ ) - NO CONING OF HOLES  
 BENDS AND ANGLES ARE  $\pm 1/2$  DEGREE  
 ALL OTHER MACHINING ( $\pm 0.030"$ )  
 ALL OTHER ASSEMBLY ( $\pm 0.060"$ )

PATENT INFORMATION: WWW.SITEPRO1.COM/PATENTS

PROPRIETARY NOTE:  
 THE DATA AND TECHNIQUES CONTAINED IN THIS DRAWING ARE PROPRIETARY INFORMATION OF VALMONT INDUSTRIES AND CONSIDERED A TRADE SECRET. ANY USE OR DISCLOSURE WITHOUT THE CONSENT OF VALMONT INDUSTRIES IS STRICTLY PROHIBITED.

DESCRIPTION  
**HEAVY S3-10-3**  
**3 - 10' NOMINAL SECTOR FRAME KIT WITH SELF-SUPPORTED / GUYED ATTACHMENT**

CPD NO. <b>NCS</b>	DRAWN BY <b>ADB 8/19/2025</b>	ENG. APPROVAL <b>8/22/2025</b>
CLASS <b>87</b>	SUB <b>02</b>	DRAWING USAGE <b>CUSTOMER</b>
	CHECKED BY <b>JET 8/22/2025</b>	



Engineering Support Team:  
 sp1engineering@valmont.com

PART NO. <b>VFA10-XDS-A3</b>
DWG. NO. <b>VFA10-XDS3-A9</b>

NOTE: MDFCC SHOWN AS REFERENCE

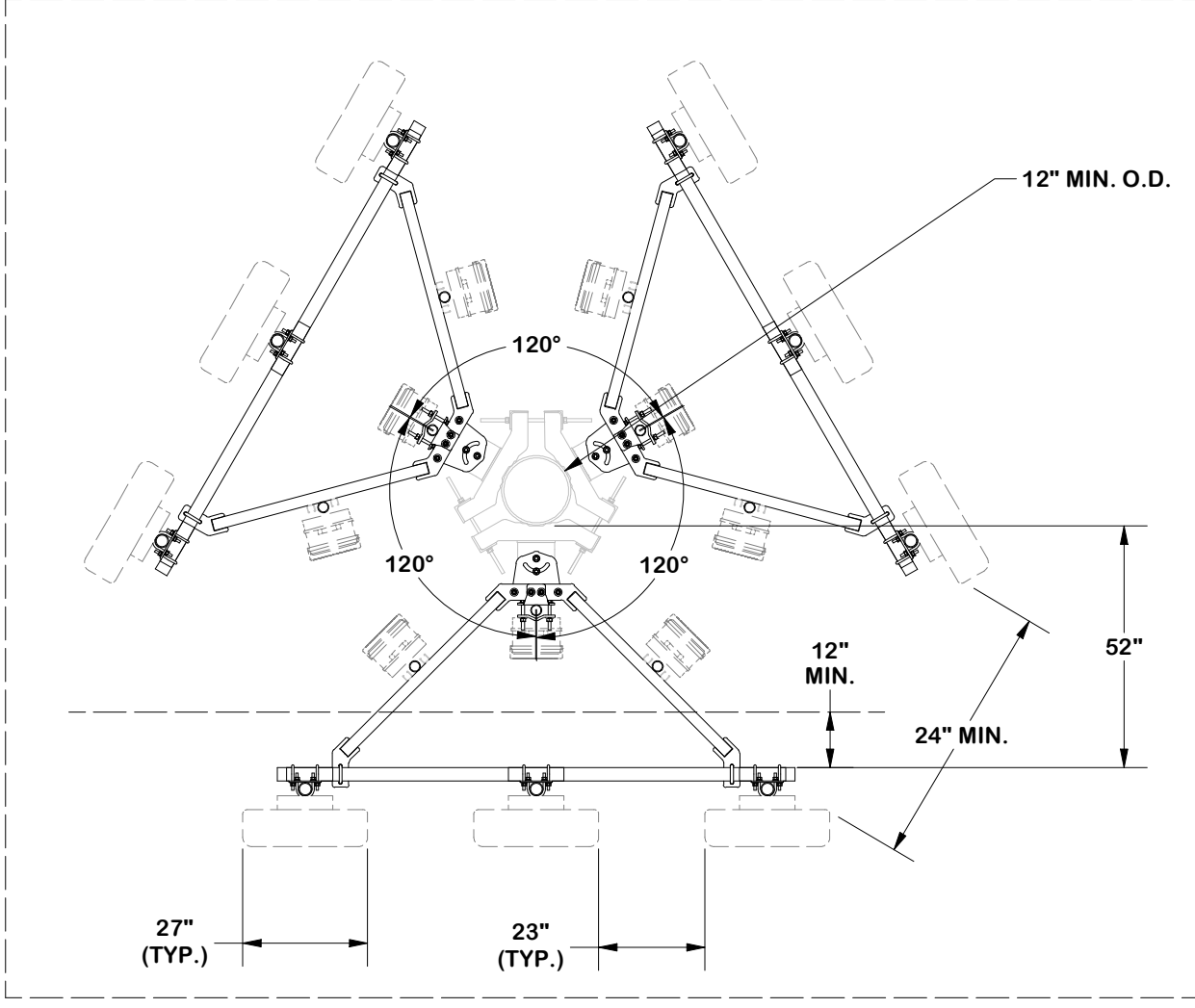
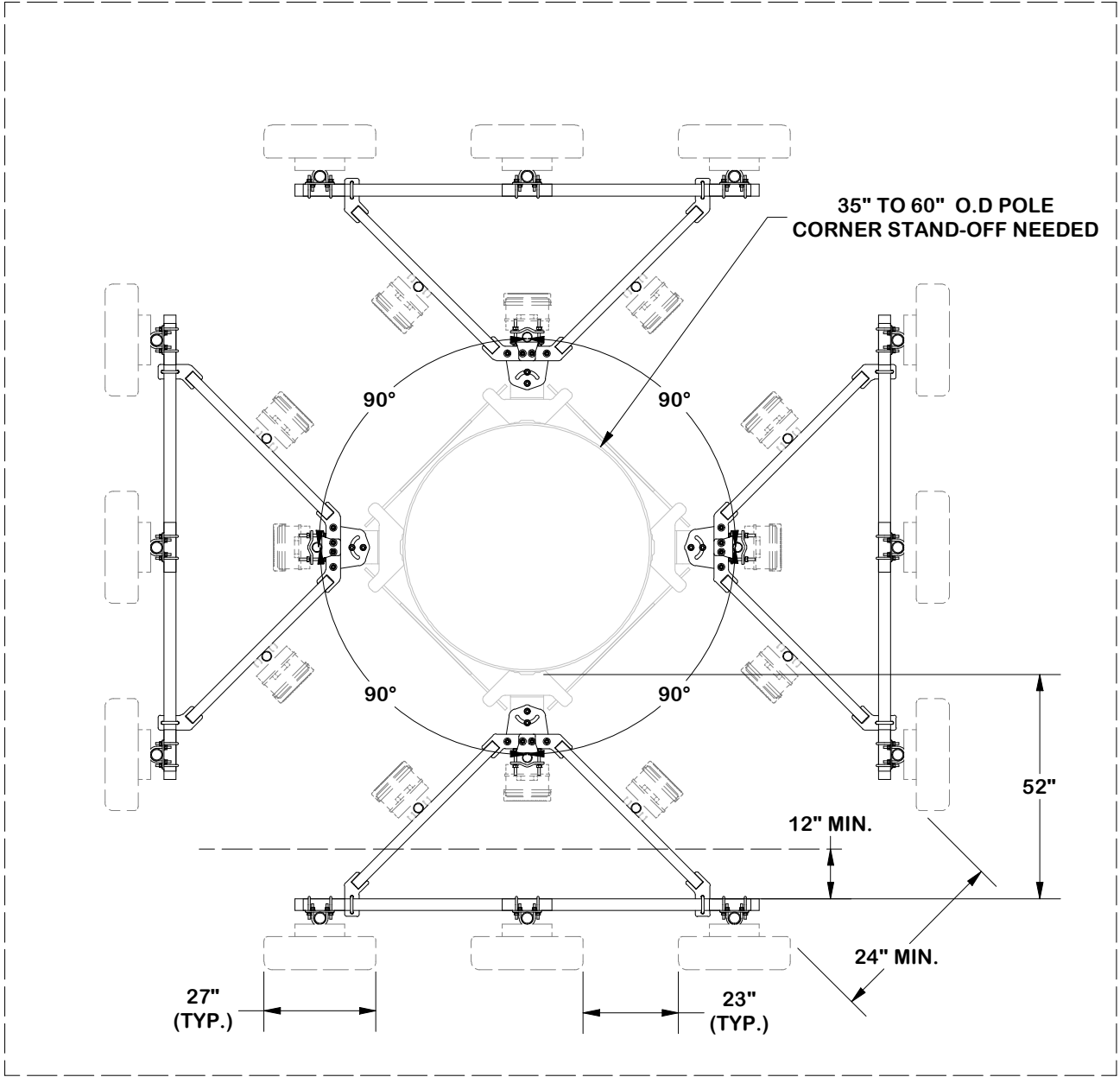

[ATT-790-202-083 MACRO BUILD COMPLIANT]

NOTE: TIEBACKS OMITTED FOR CLARITY

**TOLERANCE NOTES**

TOLERANCES ON DIMENSIONS, UNLESS OTHERWISE NOTED ARE:  
 SAWED, SHEARED AND GAS CUT EDGES ( $\pm 0.030"$ )  
 DRILLED AND GAS CUT HOLES ( $\pm 0.030"$ ) - NO CONING OF HOLES  
 LASER CUT EDGES AND HOLES ( $\pm 0.010"$ ) - NO CONING OF HOLES  
 BENDS AND ANGLES ARE  $\pm 1/2$  DEGREE  
 ALL OTHER MACHINING ( $\pm 0.030"$ )  
 ALL OTHER ASSEMBLY ( $\pm 0.060"$ )

PATENT INFORMATION: WWW.SITEPRO1.COM/PATENTS

PROPRIETARY NOTE:  
 THE DATA AND TECHNIQUES CONTAINED IN THIS DRAWING ARE PROPRIETARY INFORMATION OF VALMONT INDUSTRIES AND CONSIDERED A TRADE SECRET. ANY USE OR DISCLOSURE WITHOUT THE CONSENT OF VALMONT INDUSTRIES IS STRICTLY PROHIBITED.

DESCRIPTION

**HEAVY S3-10-3**  
**3 - 10' NOMINAL SECTOR FRAME KIT WITH**  
**SELF-SUPPORTED / GUYED ATTACHMENT**

CPD NO.	DRAWN BY	ENG. APPROVAL
NCS	ADB 8/19/2025	8/22/2025
CLASS	DRAWING USAGE	CHECKED BY
87	CUSTOMER	JET 8/22/2025

**SITE PRO 1**

Engineering Support Team:  
 sp1engineering@valmont.com

A valmont COMPANY

PART NO.	DWG. NO.
<b>CORNER LAYOUT</b>	<b>VFA10-XDS3-A9</b>

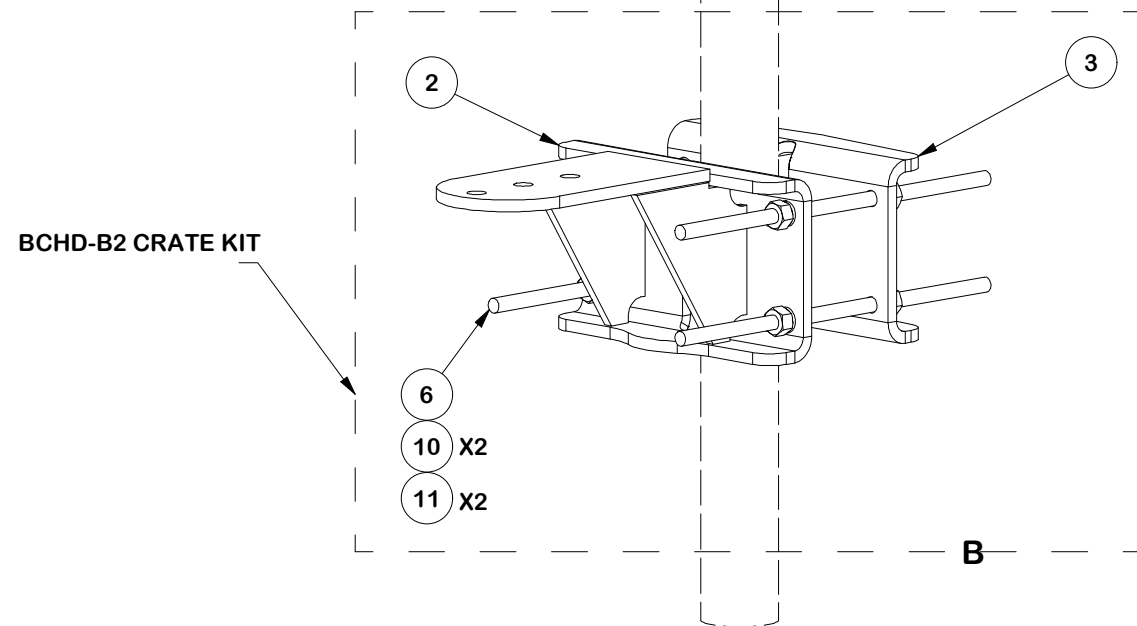
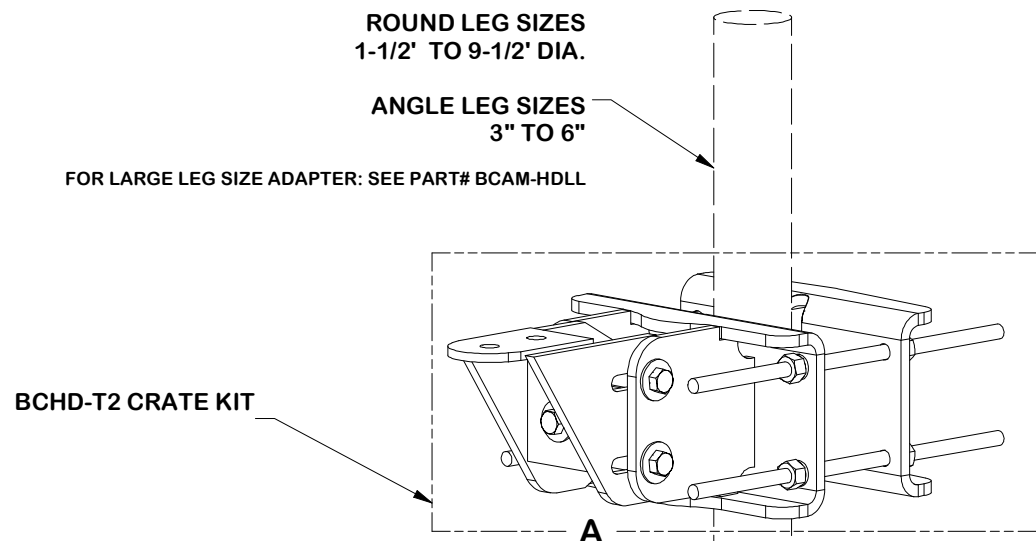

PARTS LIST						
ITEM	QTY	PART NO.	PART DESCRIPTION	LENGTH	UNIT WT.	NET WT.
1	1	X-HDCAMTBW	CLAMP WELDMENT FOR BCAM-HD		33.86	33.86
2	1	X-MHTPHD	MULTI-HOLE TAPER PLATE WELDMENT		36.24	36.24
3	2	X-LCBP4	BENT BACKING PLATE	13 in	20.04	40.09
4	1	X-HDCAMSS	ANGLE ADJUSTMENT WELDMENT FOR BCAM-HD		16.39	16.39
5	1	X-HDCAMSP	POSITIONING PLATE WELDMENT FOR BCAM-HD		2.58	2.58
6	8	G58R-18	5/8" x 18" THREADED ROD (HDG.)		1.57	12.54
7	2	G5807	5/8" x 7" HDG HEX BOLT GR5 FULL THREAD	7 in	0.70	1.41
8	1	G5806	5/8" x 6" HDG HEX BOLT GR5 FULL THREAD	6 in	0.62	0.62
9	5	G58FW	5/8" HDG USS FLATWASHER	1/8 in	0.07	0.35
10	18	G58LW	5/8" HDG LOCKWASHER		0.03	0.47
11	19	G58NUT	5/8" HDG HEAVY 2H HEX NUT		0.13	2.47
					<b>TOTAL WT. #</b>	<b>147.02</b>

**\*\* FOR DETAIL SEE PAGE 2\*\***

REV	DESCRIPTION OF REVISIONS	CPD	BY	DATE
A	REPLACED C CHANNEL BRKT WITH FORMED PLATE BRKT	SP1	ADB	4/24/2018
<b>REVISION HISTORY</b>				

TOLERANCE NOTES	
TOLERANCES ON DIMENSIONS, UNLESS OTHERWISE NOTED ARE: SAWED, SHEARED AND GAS CUT EDGES ( $\pm 0.030"$ ) DRILLED AND GAS CUT HOLES ( $\pm 0.030"$ ) - NO CONING OF HOLES LASER CUT EDGES AND HOLES ( $\pm 0.010"$ ) - NO CONING OF HOLES BENDS AND ANGLES ARE $\pm 1/2$ DEGREE ALL OTHER MACHINING ( $\pm 0.030"$ ) ALL OTHER ASSEMBLY ( $\pm 0.060"$ )	
PATENT INFORMATION: WWW.SITEPRO1.COM/PATENTS PROPRIETARY NOTE: THE DATA AND TECHNIQUES CONTAINED IN THIS DRAWING ARE PROPRIETARY INFORMATION OF VALMONT INDUSTRIES AND CONSIDERED A TRADE SECRET. ANY USE OR DISCLOSURE WITHOUT THE CONSENT OF VALMONT INDUSTRIES IS STRICTLY PROHIBITED.	

DESCRIPTION			
<b>HEAVY S3-10-3</b> <b>3 - 10' NOMINAL SECTOR FRAME KIT WITH</b> <b>SELF-SUPPORTED / GUYED ATTACHMENT</b>			
CPD NO.	DRAWN BY	ENG. APPROVAL	
NCS	ADB 8/19/2025	8/22/2025	
CLASS	SUB	DRAWING USAGE	CHECKED BY
87	02	CUSTOMER	JET 8/22/2025

 A valmont COMPANY		Engineering Support Team: sp1engineering@valmont.com
PART NO.		<b>BCAM-HD</b>
DWG. NO.		<b>VFA10-XDS3-A9</b>



**ANGLE CALIBRATING PROCEDURE:**

1. MEASURE TOWER TAPER AND PICK LOWER BRACKET HOLE:
  - HOLE A = -2.6° TO 2.6°
  - HOLE B = 1.6° TO 6.8°
2. USE CALIBRATING BOLT TO ADJUST FRAME TO DESIRED TAPER
3. TORQUE LOCKING BOLTS TO 100 ft.-lbs.
4. ADVANCE LOCKING NUT TO POSITIONING PLATE, THEN TIGHTEN.

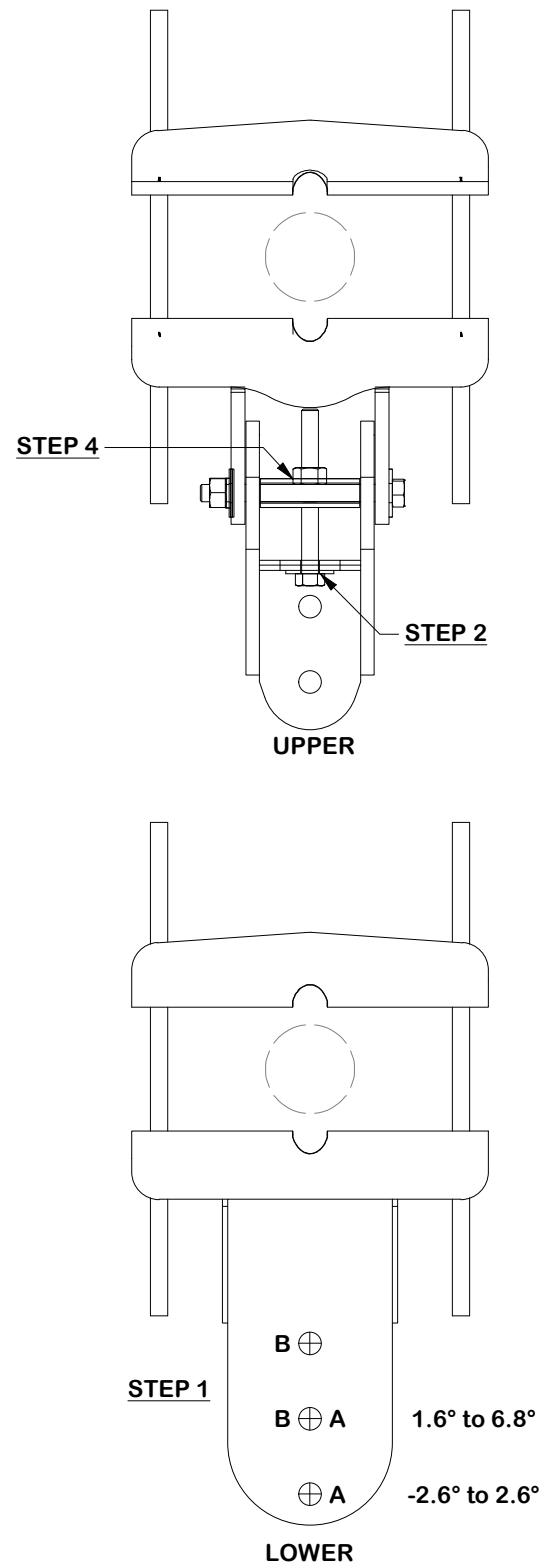

**TOLERANCE NOTES**

TOLERANCES ON DIMENSIONS, UNLESS OTHERWISE NOTED ARE:  
 SAWED, SHEARED AND GAS CUT EDGES ( $\pm 0.030"$ )  
 DRILLED AND GAS CUT HOLES ( $\pm 0.030"$ ) - NO CONING OF HOLES  
 LASER CUT EDGES AND HOLES ( $\pm 0.010"$ ) - NO CONING OF HOLES  
 BENDS AND ANGLES ARE  $\pm 1/2$  DEGREE  
 ALL OTHER MACHINING ( $\pm 0.030"$ )  
 ALL OTHER ASSEMBLY ( $\pm 0.060"$ )

PATENT INFORMATION: WWW.SITEPRO1.COM/PATENTS

PROPRIETARY NOTE:  
 THE DATA AND TECHNIQUES CONTAINED IN THIS DRAWING ARE PROPRIETARY INFORMATION OF VALMONT INDUSTRIES AND CONSIDERED A TRADE SECRET. ANY USE OR DISCLOSURE WITHOUT THE CONSENT OF VALMONT INDUSTRIES IS STRICTLY PROHIBITED.

DESCRIPTION  
**HEAVY S3-10-3**  
**3 - 10' NOMINAL SECTOR FRAME KIT WITH**  
**SELF-SUPPORTED / GUYED ATTACHMENT**

**SITE PRO 1**  
 Engineering Support Team:  
 sp1engineering@valmont.com  
 A valmont COMPANY

CPD NO. <b>NCS</b>	DRAWN BY <b>ADB 8/19/2025</b>	ENG. APPROVAL <b>8/22/2025</b>
CLASS <b>87</b>	SUB <b>02</b>	DRAWING USAGE <b>CUSTOMER</b>
CHECKED BY <b>JET 8/22/2025</b>		

PART NO. <b>BCAM-HD</b>	PAGE <b>9 OF 17</b>
DWG. NO. <b>VFA10-XDS3-A9</b>	

PARTS LIST							
ITEM	QTY	PART NO.	BOX NO.	PART DESCRIPTION	LENGTH	UNIT WT.	NET WT.
1	1	SPTB-U-F	P-SPTBU-F	UNIVERSAL SLIDING PIPE TIE BACK ASSEMBLY (FRONT CONNECTION ONLY)		19.15	19.15
2	1	SPTB-U-B	P-SPTBU-B	UNIVERSAL SLIDING PIPE TIE BACK ASSEMBLY (REAR CONNECTION ONLY)		33.22	33.22
3	1	P2120		2-3/8" x 120" (2" SCH. 40) GALVANIZED PIPE (A53 Gr.B Fy=35 ksi min.)	120 in	38.81	38.81
						TOTAL WT. #	91.18

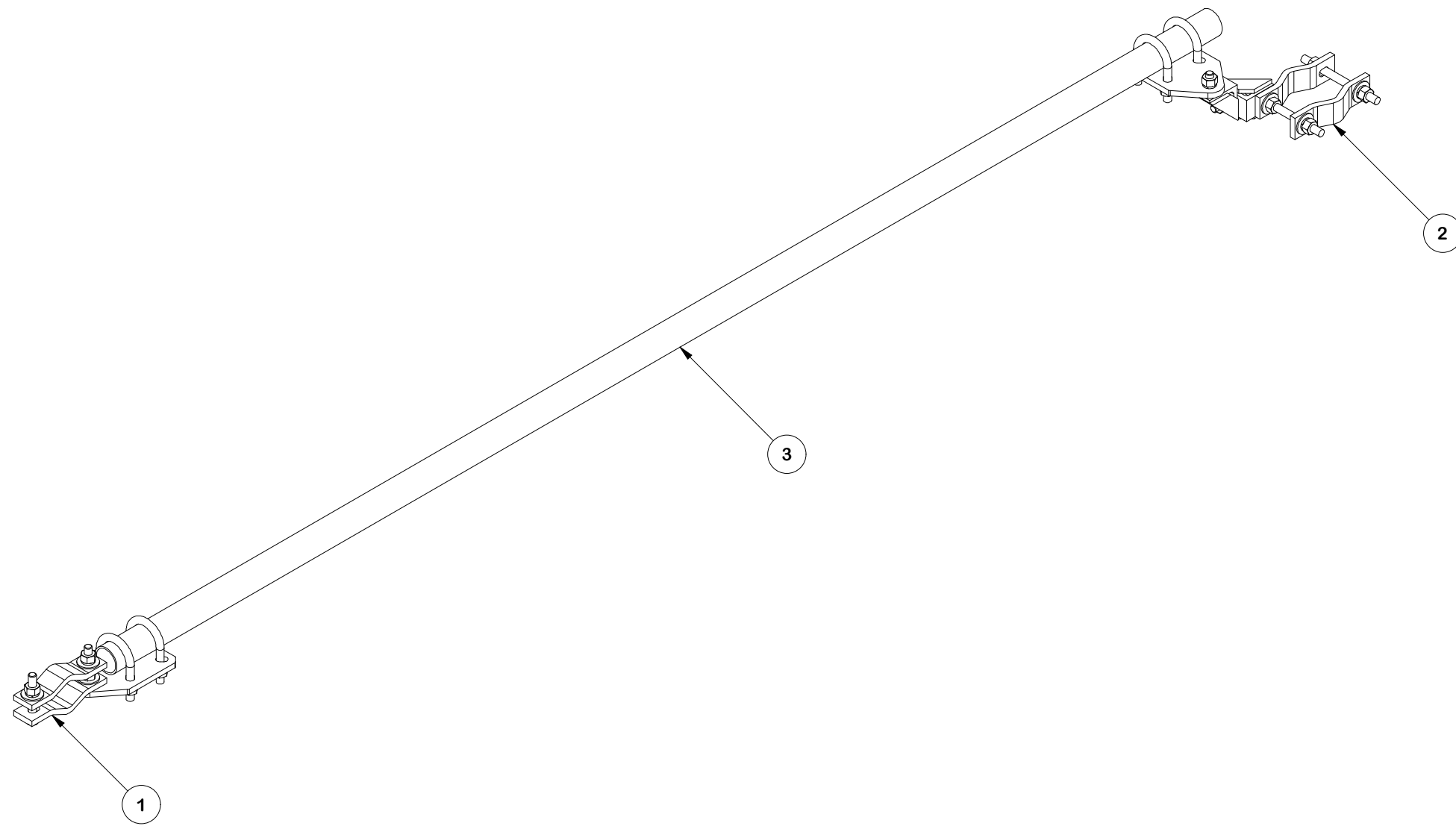

					<b>TOLERANCE NOTES</b> TOLERANCES ON DIMENSIONS, UNLESS OTHERWISE NOTED ARE: SAWED, SHEARED AND GAS CUT EDGES ( $\pm 0.030"$ ) DRILLED AND GAS CUT HOLES ( $\pm 0.030"$ ) - NO CONING OF HOLES LASER CUT EDGES AND HOLES ( $\pm 0.010"$ ) - NO CONING OF HOLES BENDS AND ANGLES ARE $\pm 1/2$ DEGREE ALL OTHER MACHINING ( $\pm 0.030"$ ) ALL OTHER ASSEMBLY ( $\pm 0.060"$ )			DESCRIPTION <b>HEAVY S3-10-3</b> <b>3 - 10' NOMINAL SECTOR FRAME KIT WITH</b> <b>SELF-SUPPORTED / GUYED ATTACHMENT</b>			 Engineering Support Team: sp1engineering@valmont.com A valmont COMPANY		
<b>A</b>	REVISED DRAWING & UPDATED X-SPTB TO X-SPTB-U	NCS	ADB	8/8/2024	PATENT INFORMATION: WWW.SITEPRO1.COM/PATENTS			CPD NO.	DRAWN BY	ENG. APPROVAL	PART NO.	10 OF 17 PAGE	
<b>REV</b>	DESCRIPTION OF REVISIONS	CPD	BY	DATE	PROPRIETARY NOTE: THE DATA AND TECHNIQUES CONTAINED IN THIS DRAWING ARE PROPRIETARY INFORMATION OF VALMONT INDUSTRIES AND CONSIDERED A TRADE SECRET. ANY USE OR DISCLOSURE WITHOUT THE CONSENT OF VALMONT INDUSTRIES IS STRICTLY PROHIBITED.			CLASS	SUB	DRAWING USAGE	CHECKED BY		DWG. NO.
<b>REVISION HISTORY</b>								<b>87</b>	<b>02</b>	<b>CUSTOMER</b>	<b>JET</b>	<b>SPTB</b>	
										<b>8/22/2025</b>	<b>VFA10-XDS3-A9</b>		

**RECOMMENDED HORIZONTAL ADJUSTMENT**

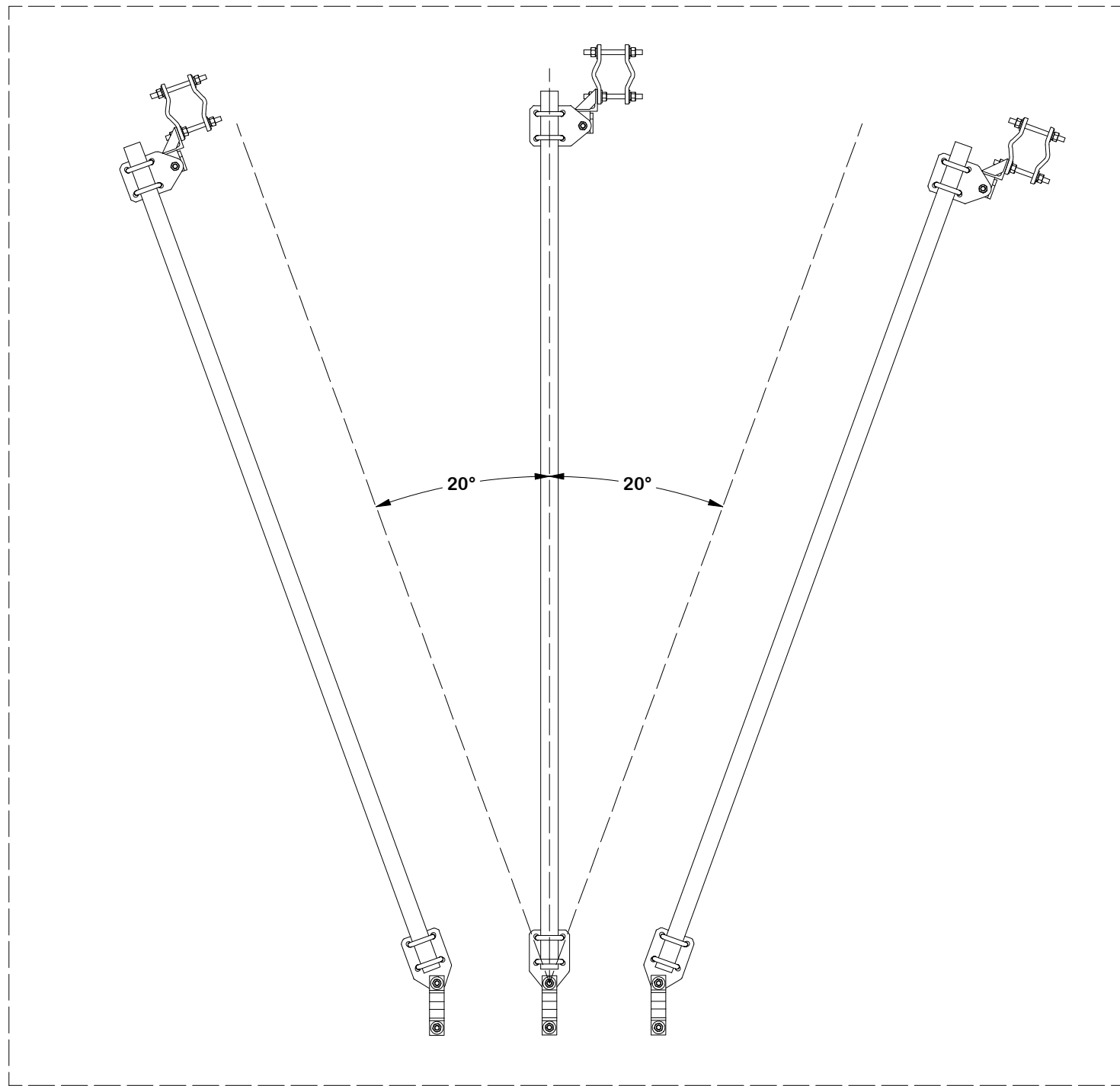

- 20 DEG.    0 DEG.    + 20 DEG.

**RECOMMENDED VERTICAL ADJUSTMENT**

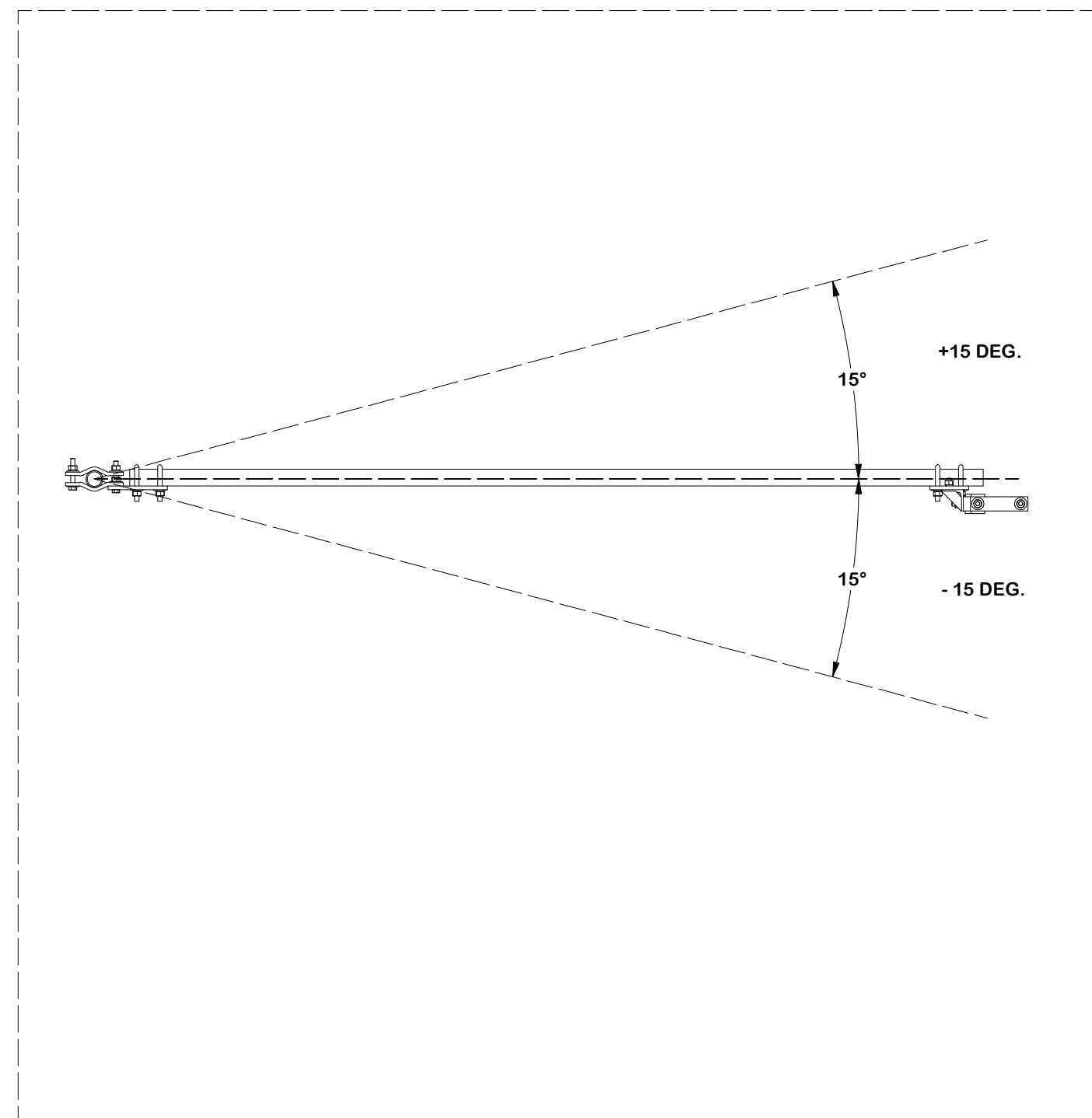

**TOLERANCE NOTES**

TOLERANCES ON DIMENSIONS, UNLESS OTHERWISE NOTED ARE:  
 SAWED, SHEARED AND GAS CUT EDGES ( $\pm 0.030"$ )  
 DRILLED AND GAS CUT HOLES ( $\pm 0.030"$ ) - NO CONING OF HOLES  
 LASER CUT EDGES AND HOLES ( $\pm 0.010"$ ) - NO CONING OF HOLES  
 BENDS AND ANGLES ARE  $\pm 1/2$  DEGREE  
 ALL OTHER MACHINING ( $\pm 0.030"$ )  
 ALL OTHER ASSEMBLY ( $\pm 0.060"$ )

PATENT INFORMATION: WWW.SITEPRO1.COM/PATENTS

PROPRIETARY NOTE:  
 THE DATA AND TECHNIQUES CONTAINED IN THIS DRAWING ARE PROPRIETARY INFORMATION OF VALMONT INDUSTRIES AND CONSIDERED A TRADE SECRET. ANY USE OR DISCLOSURE WITHOUT THE CONSENT OF VALMONT INDUSTRIES IS STRICTLY PROHIBITED.

DESCRIPTION  
**HEAVY S3-10-3**  
**3 - 10' NOMINAL SECTOR FRAME KIT WITH**  
**SELF-SUPPORTED / GUYED ATTACHMENT**

CPD NO. <b>NCS</b>	DRAWN BY <b>ADB 8/19/2025</b>	ENG. APPROVAL <b>8/22/2025</b>
CLASS <b>87</b>	SUB <b>02</b>	DRAWING USAGE <b>CUSTOMER</b>
	CHECKED BY <b>JET 8/22/2025</b>	



Engineering Support Team:  
 sp1engineering@valmont.com

PART NO. <b>SPTB</b>
DWG. NO. <b>VFA10-XDS3-A9</b>

PARTS LIST						
ITEM	QTY	PART NO.	PART DESCRIPTION	LENGTH	UNIT WT.	NET WT.
1	1	X-SPTB-U	SLIDING PIPE TIE BACK PLATE	5 1/2 in	5.58	5.58
2	2	DCP	1/2" THICK, 5-3/4" CNTER TO CENTER CLAMP HALF	8 1/8 in	2.36	4.72
3	2	X-UB5258	5/8 X 2-5/8" X 4-1/2" X 2" U-BOLT	4 1/2 in	1.06	2.12
4	2	X-UB5300	5/8" X 3" X 5-1/4" X 2-1/2" U-BOLT	5 1/4 in	1.22	2.43
5	2	G58R-8	5/8" x 8" THREADED ROD (HDG.)		0.70	1.39
6	2	G5804	5/8" x 4" HDG HEX BOLT GR5		0.44	0.89
7	9	G58FW	5/8" HDG USS FLATWASHER	1/8 in	0.07	0.63
8	8	G58LW	5/8" HDG LOCKWASHER		0.03	0.21
9	9	G58NUT	5/8" HDG HEAVY 2H HEX NUT		0.13	1.17
					TOTAL WT. #	19.15

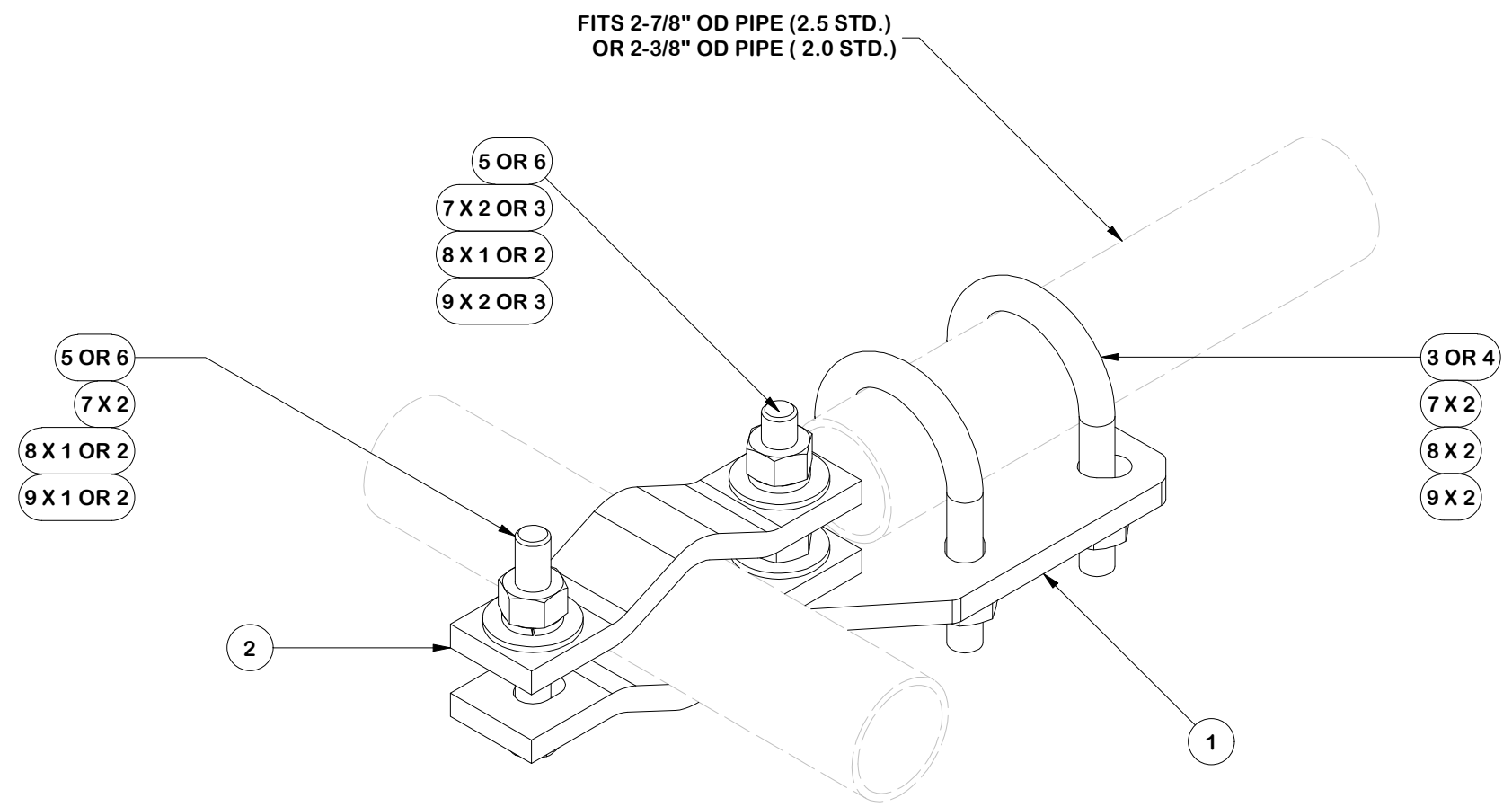

**TOLERANCE NOTES**

TOLERANCES ON DIMENSIONS, UNLESS OTHERWISE NOTED ARE:  
 SAWED, SHEARED AND GAS CUT EDGES ( $\pm 0.030"$ )  
 DRILLED AND GAS CUT HOLES ( $\pm 0.030"$ ) - NO CONING OF HOLES  
 LASER CUT EDGES AND HOLES ( $\pm 0.010"$ ) - NO CONING OF HOLES  
 BENDS AND ANGLES ARE  $\pm 1/2$  DEGREE  
 ALL OTHER MACHINING ( $\pm 0.030"$ )  
 ALL OTHER ASSEMBLY ( $\pm 0.060"$ )

PATENT INFORMATION: WWW.SITEPRO1.COM/PATENTS

DESCRIPTION

**HEAVY S3-10-3**  
**3 - 10' NOMINAL SECTOR FRAME KIT WITH**  
**SELF-SUPPORTED / GUYED ATTACHMENT**

**SITE PRO 1**  
 A valmont COMPANY

Engineering Support Team:  
 sp1engineering@valmont.com

PART NO. **SPTB-U-F**

DWG. NO. **VFA10-XDS3-A9**

PROPRIETARY NOTE:  
 THE DATA AND TECHNIQUES CONTAINED IN THIS DRAWING ARE PROPRIETARY INFORMATION OF VALMONT INDUSTRIES AND CONSIDERED A TRADE SECRET. ANY USE OR DISCLOSURE WITHOUT THE CONSENT OF VALMONT INDUSTRIES IS STRICTLY PROHIBITED.

CPD NO.	DRAWN BY	ENG. APPROVAL
NCS	ADB 8/19/2025	8/22/2025
CLASS	DRAWING USAGE	CHECKED BY
87	CUSTOMER	JET 8/22/2025

PAGE 12 OF 17

### FRONT FACE CONFIGURATIONS

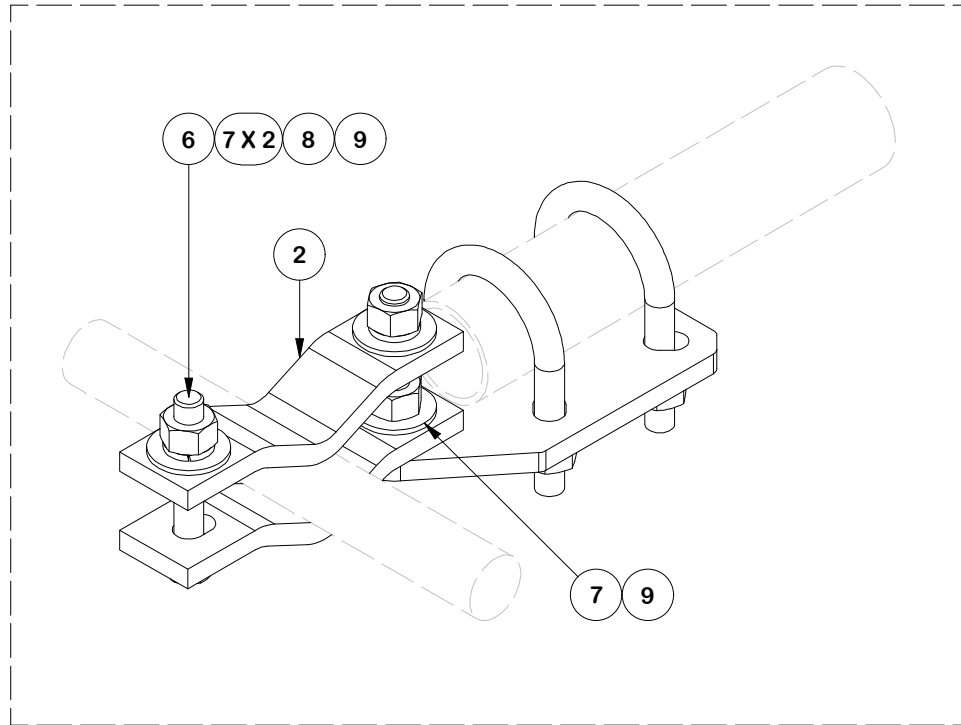

**SMALL ATTACHMENT 1-1/2" TO 2-3/8"**  
NOTE: FLIP HALF BACK CLAMP

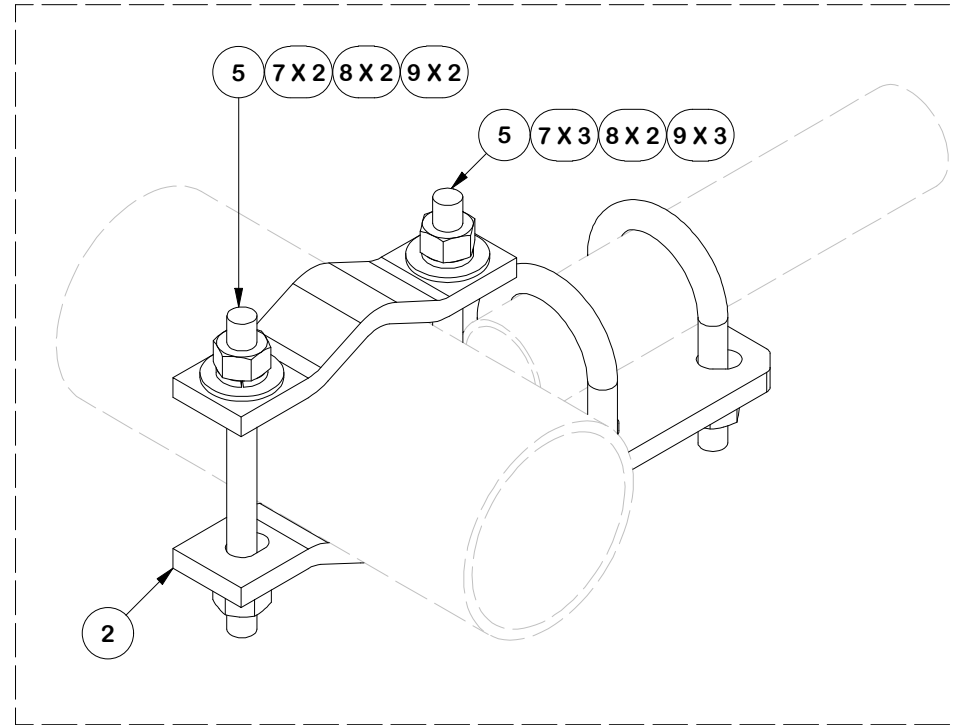

**ATTACHMENT 2-3/8" TO 5"**  
HORIZONTAL ORIENTATION

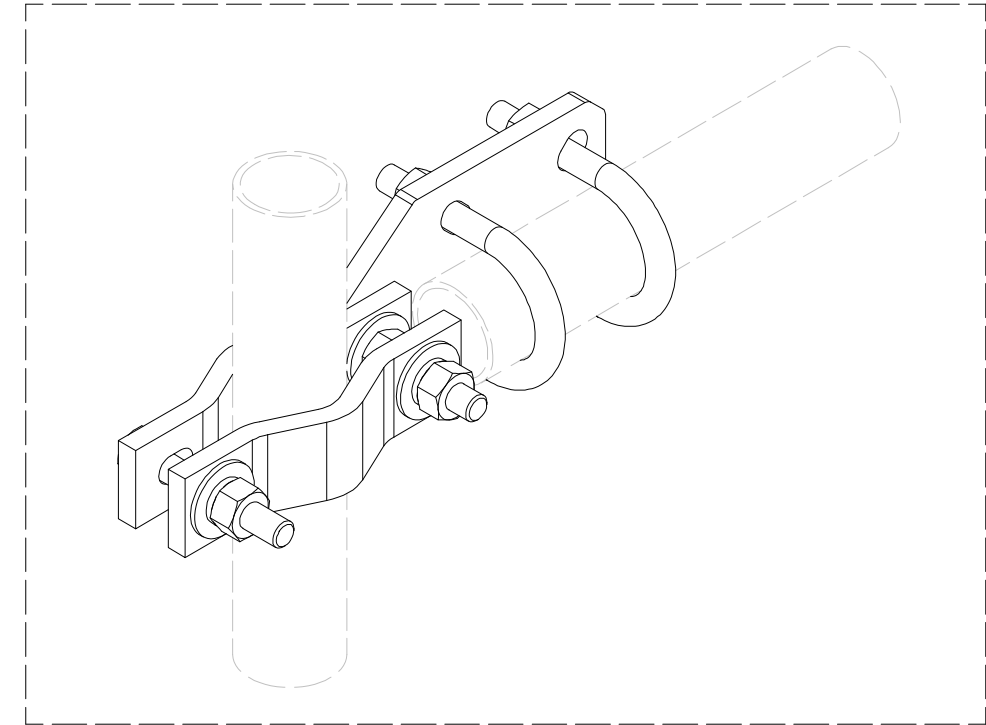

**ATTACHMENT 2-3/8" TO 5"**  
VERTICAL ORIENTATION

#### TOLERANCE NOTES

TOLERANCES ON DIMENSIONS, UNLESS OTHERWISE NOTED ARE:  
 SAWED, SHEARED AND GAS CUT EDGES ( $\pm 0.030"$ )  
 DRILLED AND GAS CUT HOLES ( $\pm 0.030"$ ) - NO CONING OF HOLES  
 LASER CUT EDGES AND HOLES ( $\pm 0.010"$ ) - NO CONING OF HOLES  
 BENDS AND ANGLES ARE  $\pm 1/2$  DEGREE  
 ALL OTHER MACHINING ( $\pm 0.030"$ )  
 ALL OTHER ASSEMBLY ( $\pm 0.060"$ )

PATENT INFORMATION: WWW.SITEPRO1.COM/PATENTS

PROPRIETARY NOTE:  
 THE DATA AND TECHNIQUES CONTAINED IN THIS DRAWING ARE PROPRIETARY INFORMATION OF VALMONT INDUSTRIES AND CONSIDERED A TRADE SECRET. ANY USE OR DISCLOSURE WITHOUT THE CONSENT OF VALMONT INDUSTRIES IS STRICTLY PROHIBITED.

DESCRIPTION  
**HEAVY S3-10-3**  
**3 - 10' NOMINAL SECTOR FRAME KIT WITH**  
**SELF-SUPPORTED / GUYED ATTACHMENT**

CPD NO. <b>NCS</b>	DRAWN BY <b>ADB 8/19/2025</b>	ENG. APPROVAL <b>8/22/2025</b>
CLASS <b>87</b>	SUB <b>02</b>	DRAWING USAGE <b>CUSTOMER</b>
	CHECKED BY <b>JET 8/22/2025</b>	



Engineering Support Team:  
 sp1engineering@valmont.com

PART NO. <b>SPTB-U-F</b>
DWG. NO. <b>VFA10-XDS3-A9</b>

PARTS LIST						
ITEM	QTY	PART NO.	PART DESCRIPTION	LENGTH	UNIT WT.	NET WT.
1	1	X-SPTB-U	SLIDING PIPE TIE BACK PLATE	5 1/2 in	5.58	5.58
2	2	X-TBCA	TIE BACK CLIP ANGLE		2.01	4.01
3	2	MCP	CLAMP HALF 1/2" THICK, 11-5/8" LONG	12 1/16 in	3.59	7.19
4	2	DCP	1/2" THICK, 5-3/4" CNTR TO CENTER CLAMP HALF	8 1/8 in	2.36	4.72
5	2	X-UB5258	5/8 X 2-5/8" X 4-1/2" X 2" U-BOLT	4 1/2 in	1.06	2.12
6	2	X-UB5300	5/8" X 3" X 5-1/4" X 2-1/2" U-BOLT	5 1/4 in	1.22	2.43
7	2	G58R-12	5/8" x 12" THREADED ROD (HDG.)		1.05	2.09
8	2	G58R-8	5/8" x 8" THREADED ROD (HDG.)		0.70	1.39
9	2	G5804	5/8" x 4" HDG HEX BOLT GR5		0.44	0.89
10	2	G5802	5/8" x 2" HDG HEX BOLT GR5		0.27	0.54
11	8	G58FW	5/8" HDG USS FLATWASHER	1/8 in	0.07	0.56
12	10	G58LW	5/8" HDG LOCKWASHER		0.03	0.26
13	11	G58NUT	5/8" HDG HEAVY 2H HEX NUT		0.13	1.43
					TOTAL WT. #	33.22

FITS 1-1/2" TO 8-5/8" OD TOWER LEGS  
60° ANGLE LEGS UP TO 8"  
90° ANGLE LEGS UP TO 6"

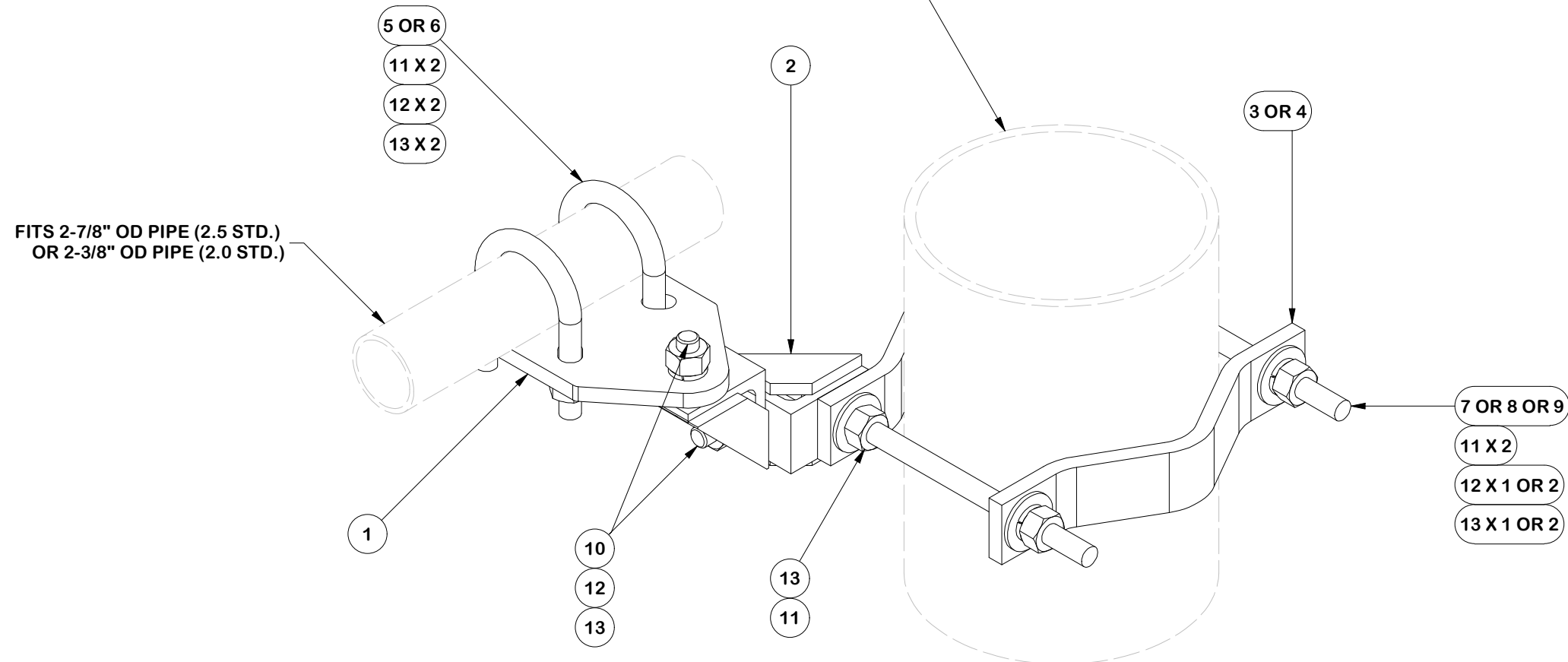

**TOLERANCE NOTES**

TOLERANCES ON DIMENSIONS, UNLESS OTHERWISE NOTED ARE:  
SAWED, SHEARED AND GAS CUT EDGES ( $\pm 0.030"$ )  
DRILLED AND GAS CUT HOLES ( $\pm 0.030"$ ) - NO CONING OF HOLES  
LASER CUT EDGES AND HOLES ( $\pm 0.010"$ ) - NO CONING OF HOLES  
BENDS AND ANGLES ARE  $\pm 1/2$  DEGREE  
ALL OTHER MACHINING ( $\pm 0.030"$ )  
ALL OTHER ASSEMBLY ( $\pm 0.060"$ )

PATENT INFORMATION: WWW.SITEPRO1.COM/PATENTS

PROPRIETARY NOTE:  
THE DATA AND TECHNIQUES CONTAINED IN THIS DRAWING ARE PROPRIETARY INFORMATION OF VALMONT INDUSTRIES AND CONSIDERED A TRADE SECRET. ANY USE OR DISCLOSURE WITHOUT THE CONSENT OF VALMONT INDUSTRIES IS STRICTLY PROHIBITED.

DESCRIPTION  
**HEAVY S3-10-3  
3 - 10' NOMINAL SECTOR FRAME KIT WITH  
SELF-SUPPORTED / GUYED ATTACHMENT**

CPD NO. <b>NCS</b>	DRAWN BY <b>ADB 8/19/2025</b>	ENG. APPROVAL <b>8/22/2025</b>
CLASS <b>87</b>	SUB <b>02</b>	DRAWING USAGE <b>CUSTOMER</b>
CHECKED BY <b>JET 8/22/2025</b>		



Engineering Support Team:  
sp1engineering@valmont.com

PART NO. <b>SPTB-U-B</b>
DWG. NO. <b>VFA10-XDS3-A9</b>

# TOWER LEG CONFIGURATIONS

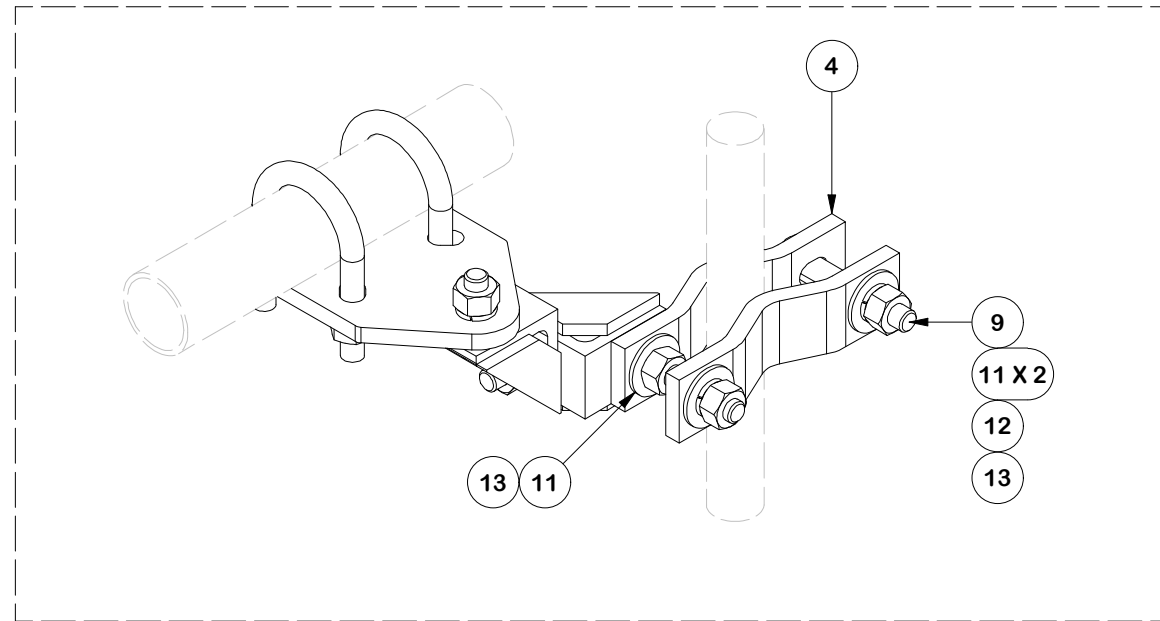

**SMALL LEGS 1-1/2" TO 2-3/8"**  
NOTE: FLIP HALF BACK CLAMP

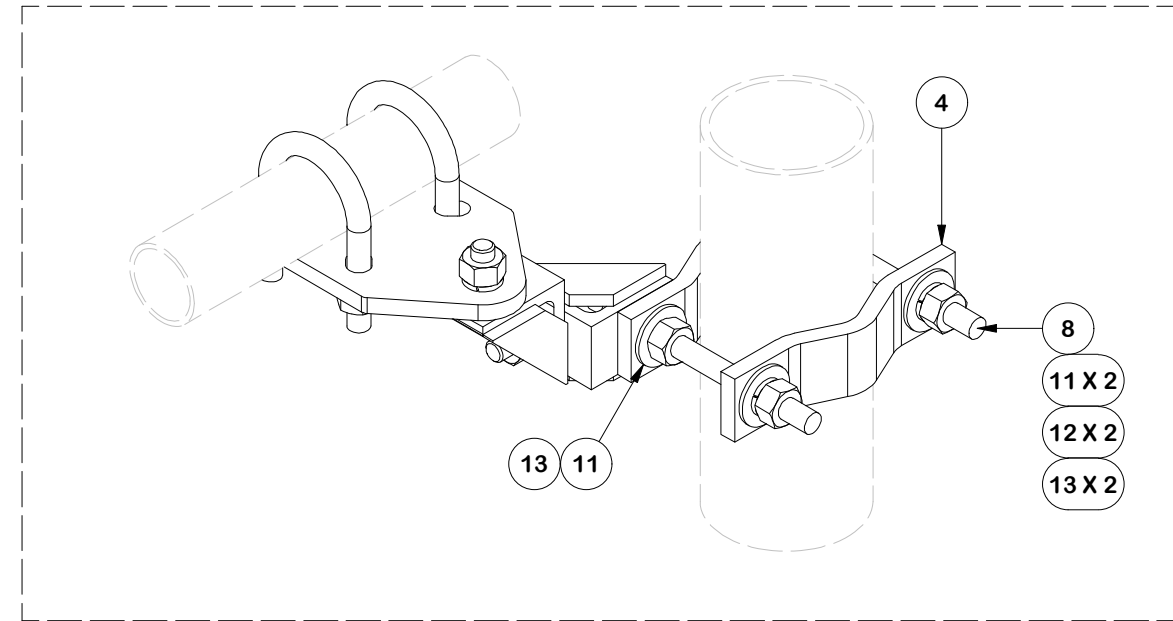

**MEDIUM LEGS 2-7/8" TO 5"**  
NOTE: FLIP HALF BACK CLAMP FOR ANGLE

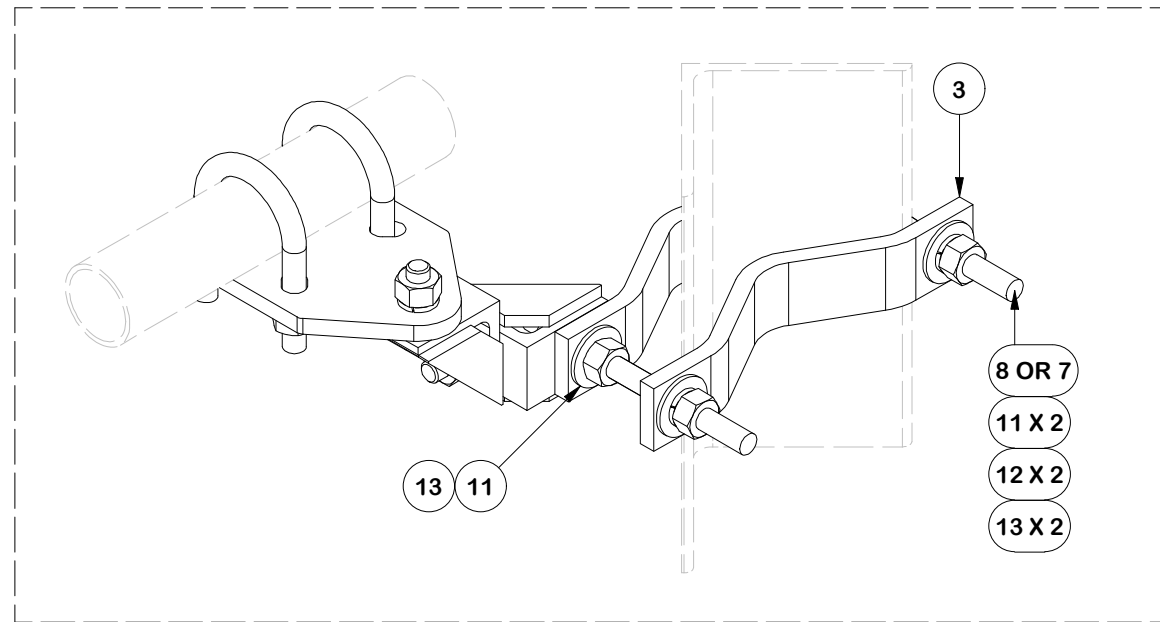

**LARGE LEGS UP TO 6" 90 DEG. 8" 60 DEG**  
NOTE: FLIP HALF BACK CLAMP

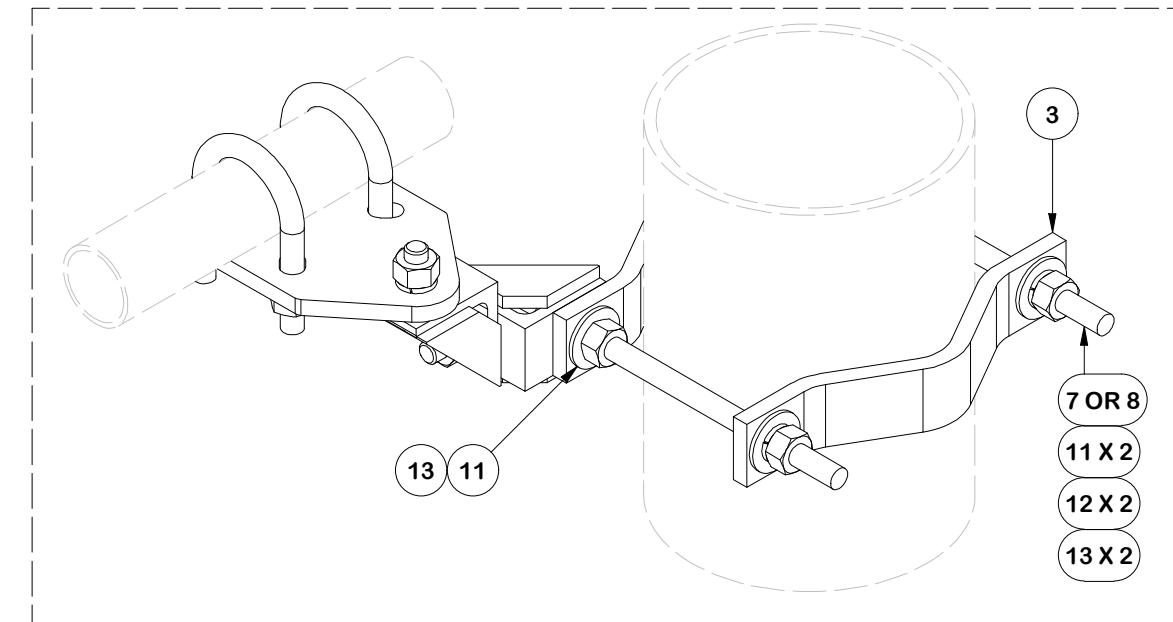

**LARGE LEGS 5" TO 8-5/8" OD**

### TOLERANCE NOTES

TOLERANCES ON DIMENSIONS, UNLESS OTHERWISE NOTED ARE:  
 SAWED, SHEARED AND GAS CUT EDGES ( $\pm 0.030"$ )  
 DRILLED AND GAS CUT HOLES ( $\pm 0.030"$ ) - NO CONING OF HOLES  
 LASER CUT EDGES AND HOLES ( $\pm 0.010"$ ) - NO CONING OF HOLES  
 BENDS AND ANGLES ARE  $\pm 1/2$  DEGREE  
 ALL OTHER MACHINING ( $\pm 0.030"$ )  
 ALL OTHER ASSEMBLY ( $\pm 0.060"$ )

PATENT INFORMATION: WWW.SITEPRO1.COM/PATENTS

PROPRIETARY NOTE:  
 THE DATA AND TECHNIQUES CONTAINED IN THIS DRAWING ARE PROPRIETARY INFORMATION OF VALMONT INDUSTRIES AND CONSIDERED A TRADE SECRET. ANY USE OR DISCLOSURE WITHOUT THE CONSENT OF VALMONT INDUSTRIES IS STRICTLY PROHIBITED.

DESCRIPTION  
**HEAVY S3-10-3**  
**3 - 10' NOMINAL SECTOR FRAME KIT WITH**  
**SELF-SUPPORTED / GUYED ATTACHMENT**

CPD NO. <b>NCS</b>	DRAWN BY <b>ADB 8/19/2025</b>	ENG. APPROVAL <b>8/22/2025</b>
CLASS <b>87</b>	SUB <b>02</b>	DRAWING USAGE <b>CUSTOMER</b>
	CHECKED BY <b>JET 8/22/2025</b>	



Engineering Support Team:  
 sp1engineering@valmont.com

PART NO. <b>SPTB-U-B</b>
DWG. NO. <b>VFA10-XDS3-A9</b>

PARTS LIST						
ITEM	QTY	PART NO.	PART DESCRIPTION	LENGTH	UNIT WT.	NET WT.
1	2	X-VFAPL4	VFA-HD PIVOT PLATE	12 in	15.88	31.77
2	4	A34212	3/4" x 2-1/2" UNC HEX BOLT (A325)	2 1/2 in	0.48	1.92
3	4	G34FW	3/4" HDG USS FLATWASHER		0.06	0.24
4	4	G34LW	3/4" HDG LOCKWASHER		0.04	0.17
5	4	G34NUT	3/4" HDG HEAVY 2H HEX NUT		0.21	0.85
6	8	A582114	5/8" x 2-1/4" HDG A325 HEX BOLT	2 1/4 in	0.31	2.50
7	8	G58FW	5/8" HDG USS FLATWASHER	1/8 in	0.07	0.56
8	8	G58LW	5/8" HDG LOCKWASHER		0.03	0.21
9	8	G58NUT	5/8" HDG HEAVY 2H HEX NUT		0.13	1.04
					TOTAL WT. #	39.25

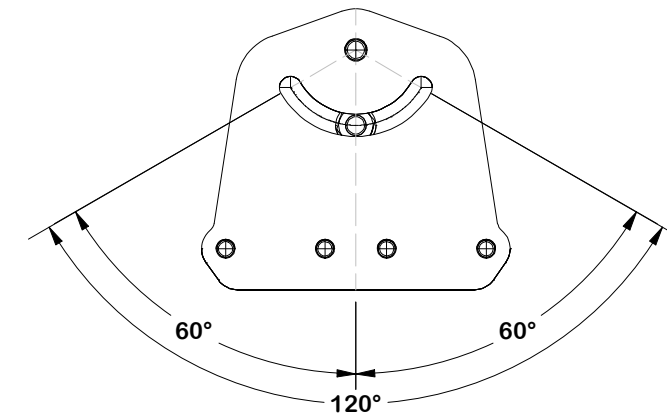
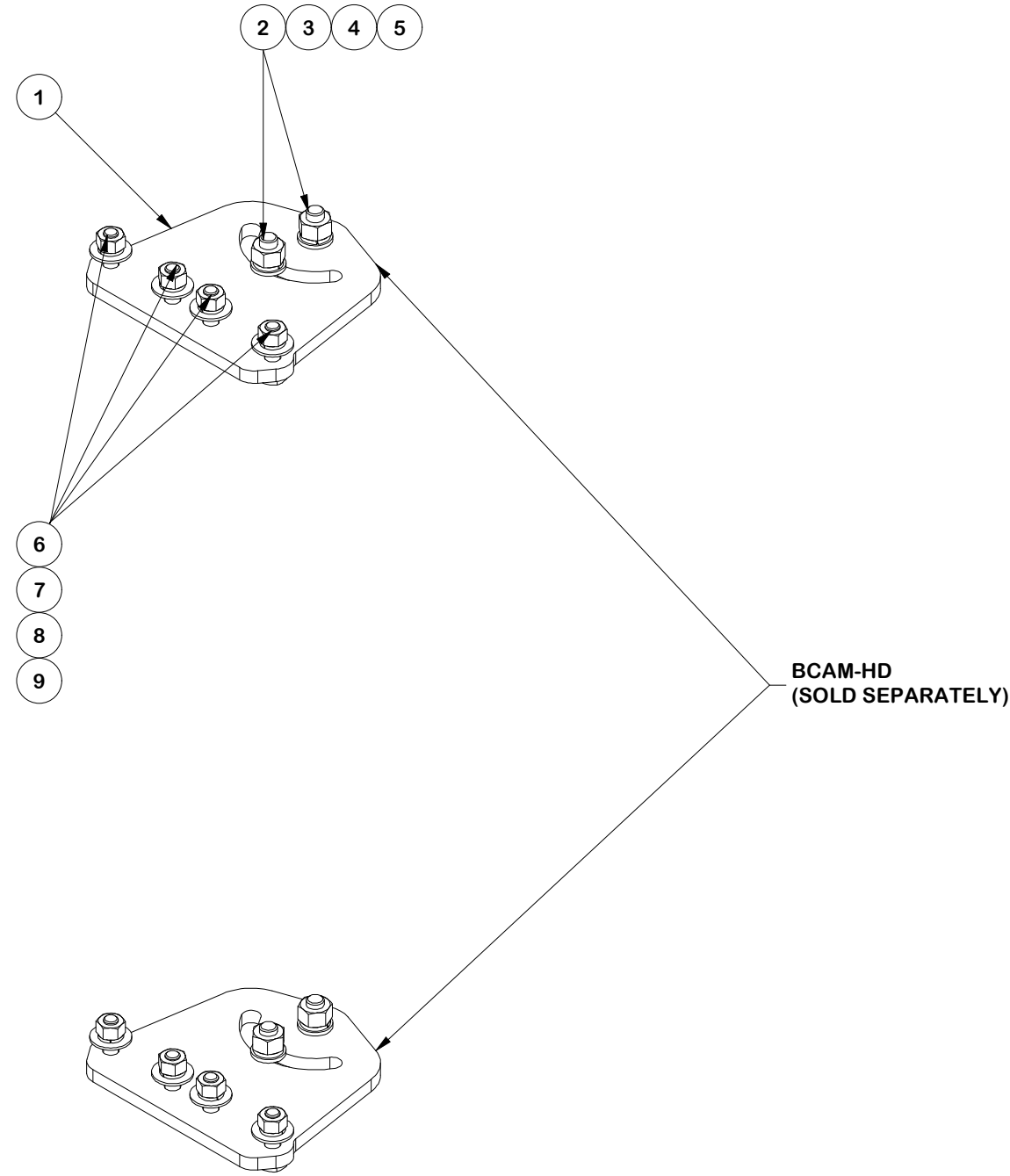

**PIVOT RANGE**

**FINISH:**  
HOT DIP GALVANIZED.

**TOLERANCE NOTES**

TOLERANCES ON DIMENSIONS, UNLESS OTHERWISE NOTED ARE:  
 SAWED, SHEARED AND GAS CUT EDGES ( $\pm 0.030"$ )  
 DRILLED AND GAS CUT HOLES ( $\pm 0.030"$ ) - NO CONING OF HOLES  
 LASER CUT EDGES AND HOLES ( $\pm 0.010"$ ) - NO CONING OF HOLES  
 BENDS AND ANGLES ARE  $\pm 1/2$  DEGREE  
 ALL OTHER MACHINING ( $\pm 0.030"$ )  
 ALL OTHER ASSEMBLY ( $\pm 0.060"$ )

PATENT INFORMATION: WWW.SITEPRO1.COM/PATENTS

PROPRIETARY NOTE:  
 THE DATA AND TECHNIQUES CONTAINED IN THIS DRAWING ARE PROPRIETARY INFORMATION OF VALMONT INDUSTRIES AND CONSIDERED A TRADE SECRET. ANY USE OR DISCLOSURE WITHOUT THE CONSENT OF VALMONT INDUSTRIES IS STRICTLY PROHIBITED.

DESCRIPTION  
**HEAVY S3-10-3**  
**3 - 10' NOMINAL SECTOR FRAME KIT WITH**  
**SELF-SUPPORTED / GUYED ATTACHMENT**



Engineering Support Team:  
 sp1engineering@valmont.com

A valmont COMPANY

CPD NO.	DRAWN BY	ENG. APPROVAL
NCS	ADB 8/19/2025	8/22/2025
CLASS	DRAWING USAGE	CHECKED BY
87	CUSTOMER	JET 8/22/2025

PART NO.	VFAPL4-K
DWG. NO.	VFA10-XDS3-A9

PARTS LIST						
ITEM	QTY	PART NO.	PART DESCRIPTION	LENGTH	UNIT WT.	NET WT.
1	1	SCX2	CROSSOVER PLATE	7 in	5.08	5.08
2	4	X-UB1300	1/2 X 3" X 5" X 2" U-BOLT	5 in	0.74	2.95
3	8	G12NUT	1/2" HDG HEAVY 2H HEX NUT	7/8 in	0.07	0.57
4	8	G12FW	1/2" HDG USS FLATWASHER	3/32 in	0.03	0.27
5	8	G12LW	1/2" HDG LOCKWASHER	1/8 in	0.01	0.11
					TOTAL WT. #	8.40

2-7/8" O.D. ANTENNA PIPE  
(ORDERED SEPARATELY)

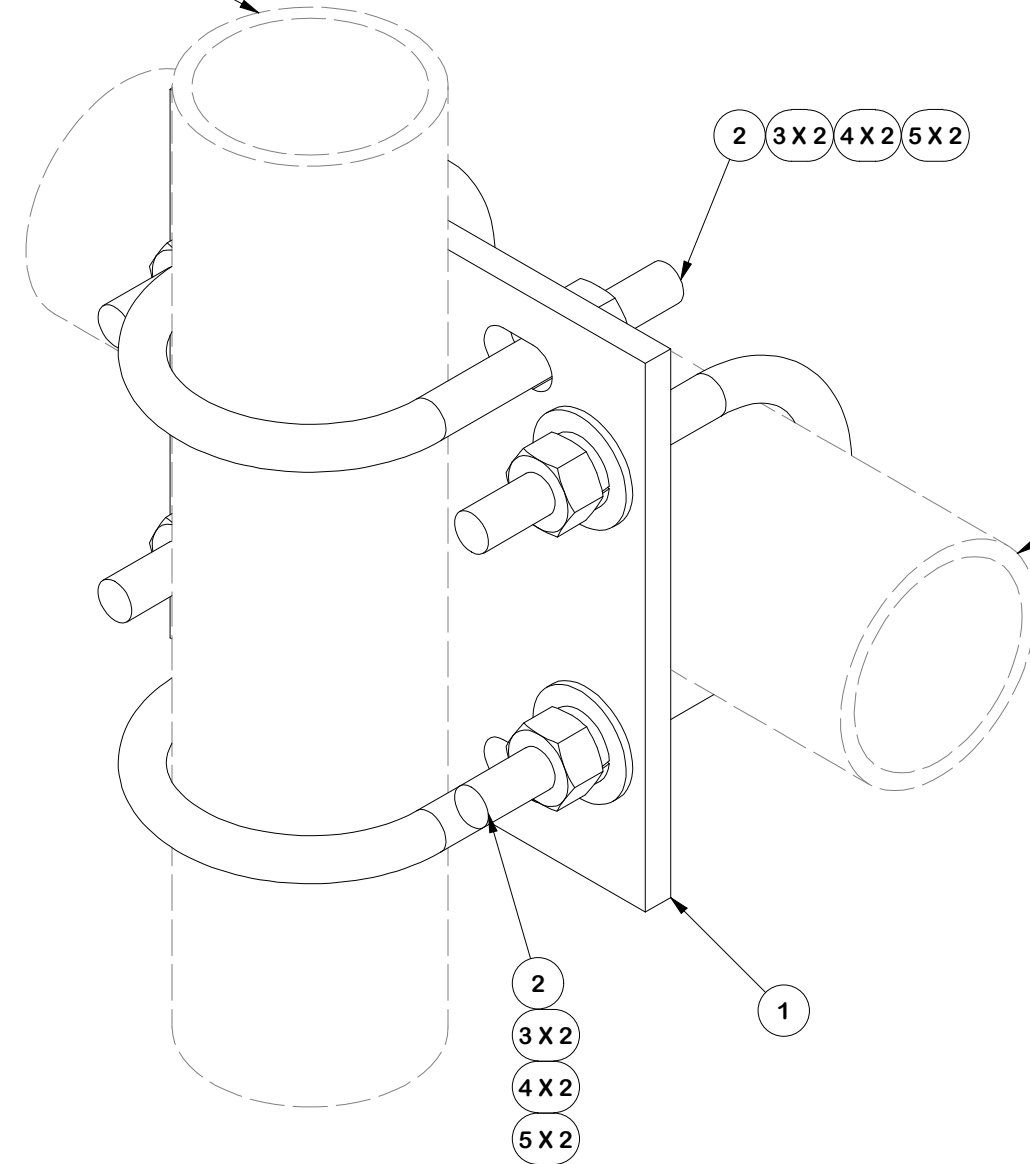

2-7/8" O.D. ANTENNA PIPE  
(ORDERED SEPARATELY)

**TOLERANCE NOTES**

TOLERANCES ON DIMENSIONS, UNLESS OTHERWISE NOTED ARE:  
 SAWED, SHEARED AND GAS CUT EDGES ( $\pm 0.030"$ )  
 DRILLED AND GAS CUT HOLES ( $\pm 0.030"$ ) - NO CONING OF HOLES  
 LASER CUT EDGES AND HOLES ( $\pm 0.010"$ ) - NO CONING OF HOLES  
 BENDS AND ANGLES ARE  $\pm 1/2$  DEGREE  
 ALL OTHER MACHINING ( $\pm 0.030"$ )  
 ALL OTHER ASSEMBLY ( $\pm 0.060"$ )

PATENT INFORMATION: WWW.SITEPRO1.COM/PATENTS

PROPRIETARY NOTE:  
 THE DATA AND TECHNIQUES CONTAINED IN THIS DRAWING ARE PROPRIETARY INFORMATION OF VALMONT INDUSTRIES AND CONSIDERED A TRADE SECRET. ANY USE OR DISCLOSURE WITHOUT THE CONSENT OF VALMONT INDUSTRIES IS STRICTLY PROHIBITED.

DESCRIPTION  
**HEAVY S3-10-3  
 3 - 10' NOMINAL SECTOR FRAME KIT WITH  
 SELF-SUPPORTED / GUYED ATTACHMENT**



Engineering Support Team:  
 sp1engineering@valmont.com

CPD NO.	DRAWN BY	ENG. APPROVAL
NCS	ADB 8/19/2025	8/22/2025
CLASS	DRAWING USAGE	CHECKED BY
87	CUSTOMER	JET 8/22/2025

PART NO.	SCX23-K
DWG. NO.	VFA10-XDS3-A9